

# TYPES SN54LS240, SN54LS241, SN54LS244, SN54S240, SN54S241, SN54S244, SN74LS240, SN74LS241, SN74LS244, SN74S240, SN74S241, SN74S244

## OCTAL BUFFERS AND LINE DRIVERS WITH 3-STATE OUTPUTS

REVISED APRIL 1985

- 3-State Outputs Drive Bus Lines or Buffer Memory Address Registers
- PNP Inputs Reduce D-C Loading
- Hysteresis at Inputs Improves Noise Margins

SN54LS', SN54S' ... J PACKAGE  
SN74LS', SN74S' ... DW, J OR N PACKAGE  
(TOP VIEW)

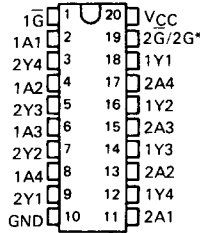

SN54LS', SN54S' ... FK PACKAGE  
SN74LS', SN74S'  
(TOP VIEW)

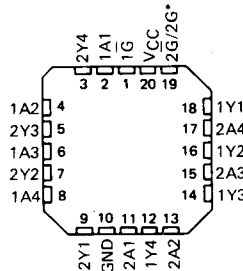

\*2G for 'LS241 and 'S241 or 2G for all other drivers.

### description

These octal buffers and line drivers are designed specifically to improve both the performance and density of three-state memory address drivers, clock drivers, and bus-oriented receivers and transmitters. The designer has a choice of selected combinations of inverting and noninverting outputs, symmetrical  $\bar{G}$  (active-low output control) inputs, and complementary  $\bar{G}$  and  $\bar{G}$  inputs. These devices feature high fan-out, improved fan-in, and 400-mV noise-margin. The SN74LS' and SN74S' can be used to drive terminated lines down to 133 ohms.

The SN54' family is characterized for operation over the full military temperature range of  $-55^{\circ}\text{C}$  to  $125^{\circ}\text{C}$ . The SN74' family is characterized for operation from  $0^{\circ}\text{C}$  to  $70^{\circ}\text{C}$ .

### schematics of inputs and outputs

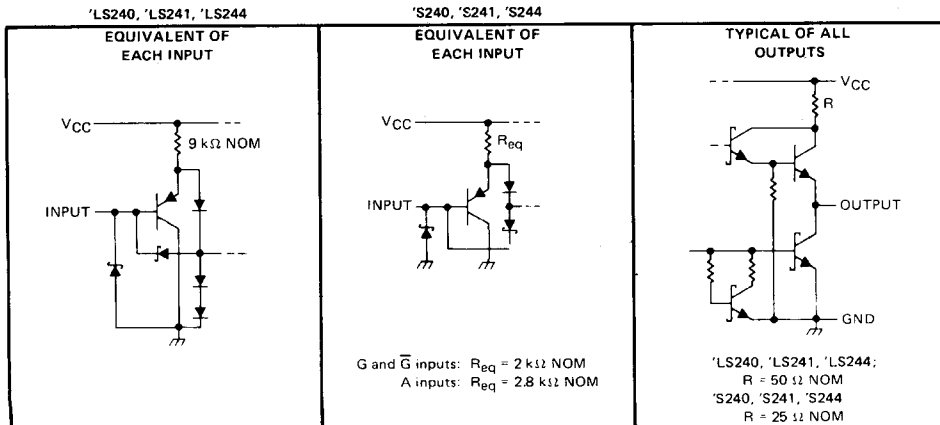

### PRODUCTION DATA

This document contains information current as of publication date. Products conform to specifications per the terms of Texas Instruments standard warranty. Production processing does not necessarily include testing of all parameters.

TEXAS  
INSTRUMENTS

3-689

3  
TTL DEVICES

# TYPES SN54LS240, SN54LS241, SN54LS244, SN54S240, SN54S241, SN54S244, SN74LS240, SN74LS241, SN74LS244, SN74S240, SN74S241, SN74S244 OCTAL BUFFERS AND LINE DRIVERS WITH 3-STATE OUTPUTS

## logic symbols

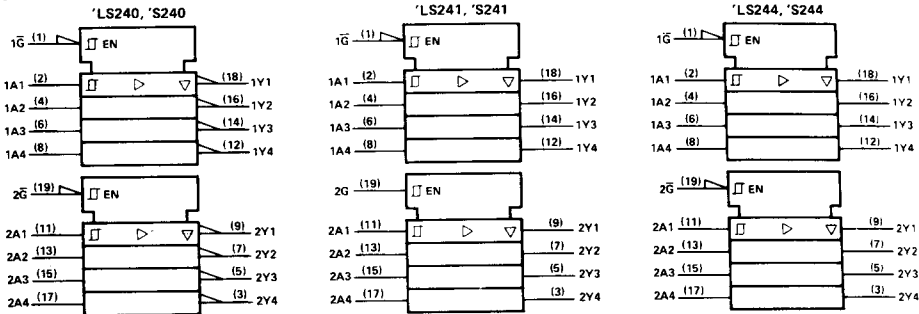

## logic diagrams (positive logic)

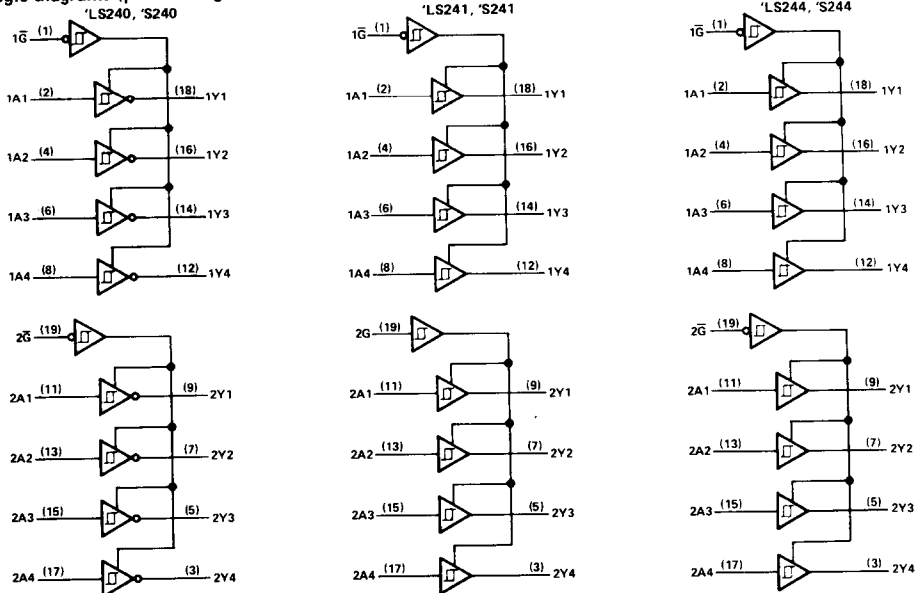

Pin numbers shown on logic notation are for DW, J or N packages.

## absolute maximum ratings over operating free-air temperature range (unless otherwise noted)

Supply voltage, $V_{CC}$ (see Note 1) . . . . .	7 V
Input voltage: 'LS Circuits . . . . .	7 V
'S Circuits . . . . .	5.5 V
Off-state output voltage . . . . .	5.5 V
Operating free-air temperature range: SN54LS', SN54S' Circuits . . . . .	- 55° C to 125° C
SN74LS', SN74S' Circuits . . . . .	0° C to 70° C
Storage temperature range . . . . .	- 65° C to 150° C

NOTE 1: Voltage values are with respect to network ground terminal.

3 TTL DEVICES

# TYPES SN54LS240, SN54LS241, SN54LS244, SN74LS240, SN74LS241, SN74LS244 OCTAL BUFFERS AND LINE DRIVERS WITH 3-STATE OUTPUTS

## recommended operating conditions

PARAMETER	SN54LS'			SN74LS'			UNIT
	MIN	NOM	MAX	MIN	NOM	MAX	
V <sub>CC</sub> Supply voltage (see Note 1)	4.5	5	5.5	4.75	5	5.25	V
V <sub>IH</sub> High-level input voltage	2			2			V
V <sub>IL</sub> Low-level input voltage	0.7			0.8			V
I <sub>OH</sub> High-level output current	-12			-15			mA
I <sub>OL</sub> Low-level output current	12			24			mA
T <sub>A</sub> Operating free-air temperature	-55			0			°C

NOTE 1: Voltage values are with respect to network ground terminal.

## electrical characteristics over recommended operating free-air temperature range (unless otherwise noted)

PARAMETER	TEST CONDITIONS†		SN54LS'		SN74LS'		UNIT	
			MIN	TYP‡	MAX	MIN		TYP‡
V <sub>IK</sub>	V <sub>CC</sub> = MIN, I <sub>I</sub> = -18 mA		-1.5		-1.5		V	
Hysteresis (V <sub>T+</sub> - V <sub>T-</sub> )	V <sub>CC</sub> = MIN		0.2	0.4	0.2	0.4	V	
V <sub>OH</sub>	V <sub>CC</sub> = MIN, V <sub>IH</sub> = 2 V, V <sub>IL</sub> = MAX, I <sub>OH</sub> = -3 mA		2.4	3.4	2.4	3.4	V	
	V <sub>CC</sub> = MIN, V <sub>IH</sub> = 2 V, V <sub>IL</sub> = 0.5 V, I <sub>OH</sub> = MAX		2		2			
V <sub>OL</sub>	V <sub>CC</sub> = MIN, V <sub>IH</sub> = 2 V, V <sub>IL</sub> = MAX		0.4		0.5		V	
	I <sub>OL</sub> = 12 mA							
I <sub>OZH</sub>	V <sub>CC</sub> = MAX, V <sub>IH</sub> = 2 V, V <sub>O</sub> = 2.7 V		20		20		μA	
	I <sub>OZL</sub> V <sub>IL</sub> = MAX, V <sub>O</sub> = 0.4 V		-20		-20			
I <sub>I</sub>	V <sub>CC</sub> = MAX, V <sub>I</sub> = 7 V		0.1		0.1		mA	
I <sub>IH</sub>	V <sub>CC</sub> = MAX, V <sub>I</sub> = 2.7 V		20		20		μA	
I <sub>IL</sub>	V <sub>CC</sub> = MAX, V <sub>IL</sub> = 0.4 V		-0.2		-0.2		mA	
I <sub>OS</sub> §	V <sub>CC</sub> = MAX		-40	-225	-40	-225	mA	
I <sub>CC</sub>	Outputs high	V <sub>CC</sub> = MAX, Output open	All	17	27	17	27	mA
	Outputs low		'LS240	26	44	26	44	
			'LS241, 'LS244	27	46	27	46	
	All outputs disabled		'LS240	29	50	29	50	
			'LS241, 'LS244	32	54	32	54	

† For conditions shown as MIN or MAX, use the appropriate value specified under recommended operating conditions.

‡ All typical values are at V<sub>CC</sub> = 5 V, T<sub>A</sub> = 25°C.

§ Not more than one output should be shorted at a time, and duration of the short circuit should not exceed one second.

## switching characteristics, V<sub>CC</sub> = 5 V, T<sub>A</sub> = 25°C

PARAMETER	TEST CONDITIONS		'LS240		'LS241, 'LS244		UNIT
			MIN	TYP	MAX	MIN	
t <sub>PLH</sub>	R <sub>L</sub> = 667 Ω, See Note 2	C <sub>L</sub> = 45 pF,	9	14	12	18	ns
t <sub>PHL</sub>			12	18	12	18	ns
t <sub>PZL</sub>			20	30	20	30	ns
t <sub>PZH</sub>	R <sub>L</sub> = 667 Ω, See Note 2	C <sub>L</sub> = 5 pF,	15	23	15	23	ns
t <sub>PLZ</sub>			10	20	10	20	ns
t <sub>PHZ</sub>			15	25	15	25	ns

NOTE 2: See General Information Section for load circuits and voltage waveforms.

3  
TTL DEVICES

# TYPES SN54S240, SN54S241, SN54S244, SN74S240, SN74S241, SN74S244 OCTAL BUFFERS AND LINE DRIVERS WITH 3-STATE OUTPUTS

## recommended operating conditions

PARAMETER	SN54S'			SN74S'			UNIT
	MIN	NOM	MAX	MIN	NOM	MAX	
V <sub>CC</sub> Supply voltage, (see Note 1)	4.5	5	5.5	4.75	5	5.25	V
V <sub>IH</sub> High-level input voltage	2			2			V
V <sub>IL</sub> Low-level input voltage	0.8			0.8			V
I <sub>OH</sub> High-level output current	-12			-15			mA
I <sub>OL</sub> Low-level output current	48			64			mA
External resistance between any input and V <sub>CC</sub> or ground	40			40			kΩ
T <sub>A</sub> Operating free-air temperature (see Note 3)	-55			125			°C

NOTES: 1. Voltage values are with respect to network ground terminal.  
 3. An SN54S241J operating at free-air temperature above 116°C requires a heat sink that provides a thermal resistance from case to free-air R<sub>θCA</sub>, of not more than 40°C/W.

## electrical characteristics over recommended operating free-air temperature range (unless otherwise noted)

PARAMETER	TEST CONDITIONS†	SN54S'			SN74S'			UNIT
		MIN	TYP‡	MAX	MIN	TYP‡	MAX	
V <sub>IK</sub>	V <sub>CC</sub> = MIN, I <sub>I</sub> = -18 mA	-1.2			-1.2			V
Hysteresis (V <sub>T+</sub> - V <sub>T-</sub> )	V <sub>CC</sub> = MIN	0.2	0.4		0.2	0.4	V	
V <sub>OH</sub>	V <sub>CC</sub> = MIN, V <sub>IH</sub> = 2 V, V <sub>IL</sub> = 0.8 V, I <sub>OH</sub> = -1 mA				2.7			V
	V <sub>CC</sub> = MIN, V <sub>IH</sub> = 2 V, V <sub>IL</sub> = 0.8 V, I <sub>OH</sub> = -3 mA	2.4	3.4		2.4	3.4		
	V <sub>CC</sub> = MIN, V <sub>IH</sub> = 2 V, V <sub>IL</sub> = 0.5 V, I <sub>OH</sub> = MAX	2			2			
V <sub>OL</sub>	V <sub>CC</sub> = MIN, V <sub>IH</sub> = 2 V, V <sub>IL</sub> = 0.8 V, I <sub>OL</sub> = MAX	0.55			0.55			V
I <sub>OZH</sub>	V <sub>CC</sub> = MAX, V <sub>IH</sub> = 2 V, V <sub>O</sub> = 2.4 V	50			50			μA
I <sub>OZL</sub>	V <sub>IL</sub> = 0.8 V, V <sub>O</sub> = 0.5 V	-50			-50			
I <sub>I</sub>	V <sub>CC</sub> = MAX, V <sub>I</sub> = 5.5 V	1			1			mA
I <sub>IH</sub>	V <sub>CC</sub> = MAX, V <sub>I</sub> = 2.7 V	50			50			μA
I <sub>IL</sub>	Any A	-400			-400			μA
	Any G	-2			-2			
I <sub>OS</sub> §	V <sub>CC</sub> = MAX	-50	-225		-50	-225	mA	
I <sub>CC</sub>	Outputs high	V <sub>CC</sub> = MAX, Outputs open	'S240	80	123	80	135	mA
			'S241, 'S244	95	147	95	160	
	Outputs low		'S240	100	145	100	150	
			'S241, 'S244	120	170	120	180	
	Outputs disabled		'S240	100	145	100	150	
			'S241, 'S244	120	170	120	180	

† For conditions shown as MIN or MAX, use the appropriate value specified under recommended operating conditions.

‡ All typical values are at V<sub>CC</sub> = 5 V, T<sub>A</sub> = 25°C.

§ Not more than one output should be shorted at a time, and duration of the short-circuit should not exceed one second.

**TYPES SN54S240, SN54S241, SN54S244, SN74S240, SN74S241, SN74S244  
OCTAL BUFFERS AND LINE DRIVERS WITH 3-STATE OUTPUTS**

switching characteristics,  $V_{CC} = 5\text{ V}$ ,  $T_A = 25^\circ\text{C}$

PARAMETER	TEST CONDITIONS	'S240			'S241, 'S244			UNIT
		MIN	TYP	MAX	MIN	TYP	MAX	
$t_{PLH}$	$R_L = 90\ \Omega$ , See Note 4 $C_L = 50\ \text{pF}$ ,	4.5		7	6		9	ns
$t_{PHL}$		4.5		7	6		9	ns
$t_{PZL}$		10		15	10		15	ns
$t_{PZH}$		6.5		10	8		12	ns
$t_{PLZ}$		10		15	10		15	ns
$t_{PHZ}$	$R_L = 90\ \Omega$ , See Note 4 $C_L = 5\ \text{pF}$ ,	6		9	6		9	ns

NOTE 4: See General Information Section for load circuits and voltage waveforms.

**3**

**TTL DEVICES**

**TYPES SN54LS240, SN54LS241, SN54LS244, SN54S240, SN54S241, SN54S244  
SN74LS240, SN74LS241, SN74LS244, SN74S240, SN74S241, SN74S244  
OCTAL BUFFERS AND LINE DRIVERS WITH 3-STATE OUTPUTS**

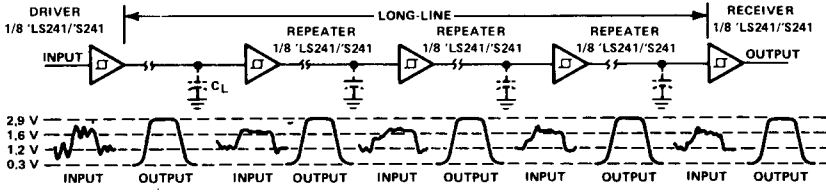

'LS241, 'S241 USED AS REPEATER/LEVEL RESTORER

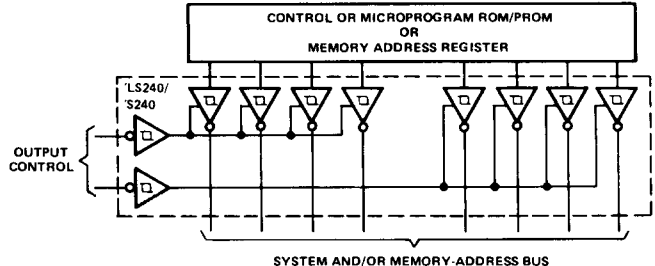

'LS240/'S240 USED AS SYSTEM AND/OR MEMORY BUS DRIVER—4 BIT ORGANIZATION CAN BE APPLIED TO HANDLE BINARY OR BCD

**3 TTL DEVICES**

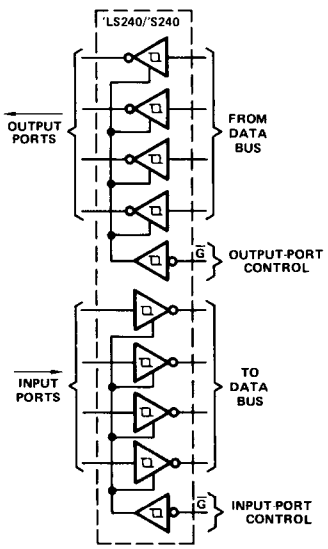

INDEPENDENT 4-BIT BUS DRIVERS/RECEIVERS IN A SINGLE PACKAGE

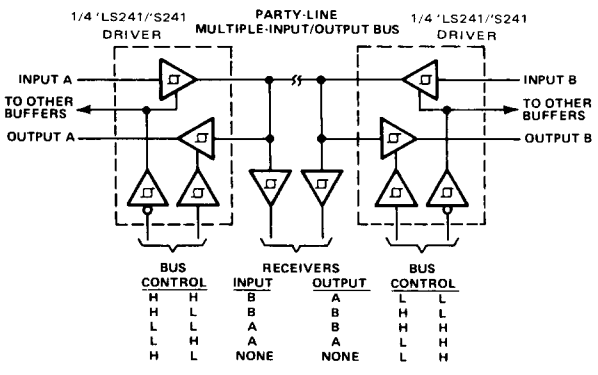

PARTY-LINE BUS SYSTEM WITH MULTIPLE INPUTS, OUTPUTS, AND RECEIVERS