

FLAME PROOF CERAMIC-INSULATED WIRE WOUND (FILM) RESISTORS

□RWB 製品紹介 INTRODUCTION OF RWB

RWB 角形巻線セメント抵抗器は、ニッケル合金抵抗線を巻いたセラミック基体またはガラスファイバー基体をシリコン含有セメントで箱型セラミックケースに封入した製品で、過負荷に極めて強い高電力抵抗器です。

RWB consists of special ceramic rod or glass fiber substrate and heat resistant Nickel alloy wound wire, sealed with silicone compound and rectangular ceramic case. Safety usage for overload and high power.

□RWB 構造 CONSTRUCTION OF RWB

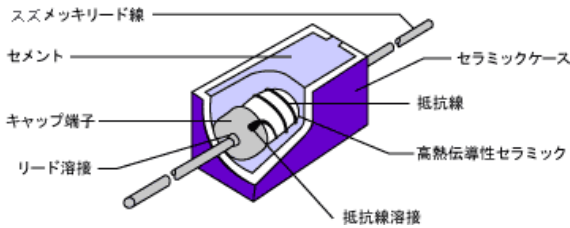

□特長 FEATURES

- 広い抵抗範囲 Wide resistance range
- 10mΩまで可能 Low resistance range selection up to 10mΩ
- 豊富な品揃え Wide products range

□特性 CHARACTERISTICS

試験項目 Test Items	規格値 Specified Values
抵抗温度係数 T.C.R.	RWB Max. ±200ppm/°C RSB Max. ±350ppm/°C
短時間過負荷 Short time overload	±(2%+0.05Ω)
耐電圧 1000V 1min Dielectric withstanding volt.	損傷のないこと Not damaged
絶縁抵抗 Insulation resistance	Over 1000MΩ
端子強度 Terminal strength	損傷のないこと Not damaged
耐久性(耐湿負荷) Moisture load life	±(5%+0.05Ω)
耐久性(定格負荷)70°C中 Load life at 70°C	±(5%+0.05Ω)
耐振性 Vibration of low frequency	±(1%+0.05Ω)
はんだ付性 Solderability	Over 95%

□負荷軽減曲線 DERATING CURVE

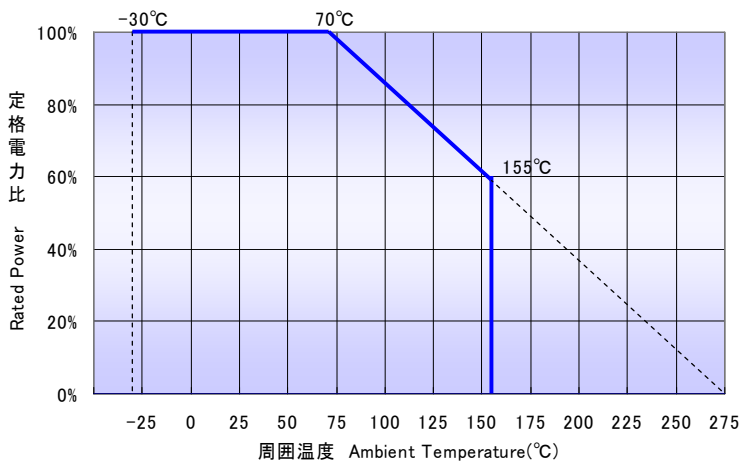

□形状 STYLE

●RWB-S RSB-S

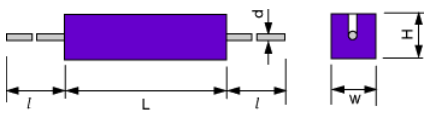

●RWB-X RSB-X

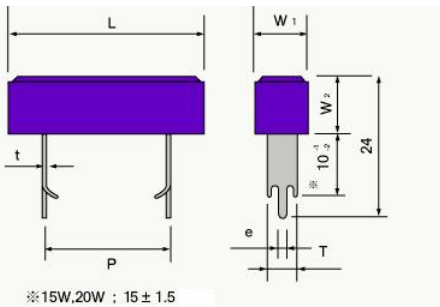

●RWB-Y RSB-Y

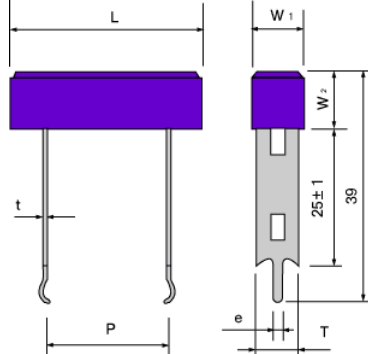

□寸法および定格 DIMENSIONS & RATING

形名 Type	定格電力 Power Rating	寸法 Dimensions(mm)					抵抗値範囲 Res.Range		許容差 Tolerance
		L±1.5	W±1	H±1	φ±3	d	RWBS	RSBS	
RWBS1, RSBS1	1W	13.5	6.0	6.0	30	0.6	10mΩ ~ 100Ω	110Ω ~ 15KΩ	±5% (J)
RWBS2, RSBS2	2W	18	6.3	6.3	35	0.8	10mΩ ~ 300Ω	330Ω ~ 20KΩ	
RWBS3, RSBS3	3W	22	8.0	8.0	35	0.8	10mΩ ~ 470Ω	510Ω ~ 39KΩ	
RWBS5, RSBS5	5W	22	9.5	9.0	35	0.8	10mΩ ~ 470Ω	510Ω ~ 51KΩ	
RWBS7, RSBS7	7W	35	9.5	9.0	35	0.8	0.1Ω ~ 470Ω	510Ω ~ 100KΩ	±10% (K)
RWBS10, RSBS10	10W	50	10.0	9.5	35	0.8	0.1Ω ~ 1KΩ	1.1KΩ ~ 150KΩ	
RWBS15, RSBS15	15W	50	12.5	12.5	35	0.8	1Ω ~ 1KΩ	1.1KΩ ~ 200KΩ	
RWBS20, RSBS20	20W	63	12.5	12.5	35	0.8	1Ω ~ 1.5KΩ	1.6KΩ ~ 240KΩ	

形名 Type	定格電力 Power Rating	寸法 Dimensions(mm)							抵抗値範囲 Resistance Range(Ω)		許容差 Tolerance	
		L±1.5	P±1	W1±1	W2±1	T	e±0.1	t	RWB□	RSB□		
RWB3, RSB3	X Y	3W	24.5	12.5	9.5	9.5	5±0.3 7.5±0.3	1.4	0.4 0.5	0.1~680	750~39K	±5% (J)
RWB5, RSB5	X Y	5W	27	15	9.5	9.5	5±0.3 7.5±0.3	1.4	0.4 0.5	0.1~680	750~51K	
RWB7, RSB7	X Y	7W	35	22.5	9.5	9.5	5±0.3 7.5±0.3	1.4	0.4 0.5	0.1~1.2K	1.3K~100K	
RWB10, RSB10	X Y	10W	48	35	9.5	9.5	5±0.3 7.5±0.3	1.4	0.4 0.5	0.1~1.8K	2K~150K	±10% (K)
RWB15, RSB15	X Y	15W	48	32.5	12.5	12.5	10±0.5 10±0.5	2.7	0.5 0.5	1~2.2K	2.4K~200K	
RWB20, RSB20	X Y	20W	63.5	50	12.5	12.5	10±0.5 10±0.5	2.7	0.5 1	1~3.3K	3.6K~240K	

・0.1Ω未満の抵抗値も製作可能です。
Resistance value less than 0.1Ω is available.
・無誘導品も製作可能です。
Non-inductive produce is also available.

□RSB 製品紹介 INTRODUCTION OF RSB

RSB 角形皮膜セメント抵抗器は、耐熱性の金属酸化皮膜を形成した高熱伝導率のアルミナセラミック基体をシリコン含有セメントと共に箱型セラミックに封入した製品で、高温安全性のある高電力抵抗器です。
RSB consists of high thermal conductivity alumina and heat resistant metal oxide film sealed with silicone compound and rectangular ceramic case. Safety usage for high temperature and high power.

□RSB 構造 CONSTRUCTION OF RSB

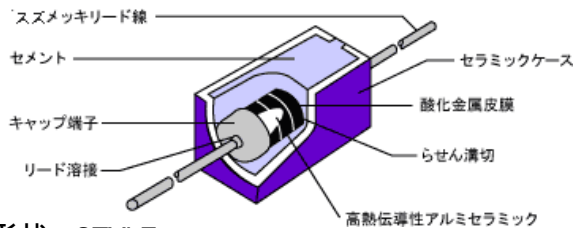

□形状 STYLE

●RWB-G RSB-G

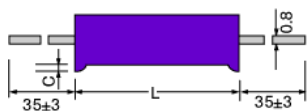

●RWB-N RSB-N

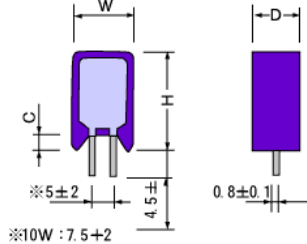

□表面温度上昇 SURFACE TEMP. RISE

R□B-S R□B-X R□B-G

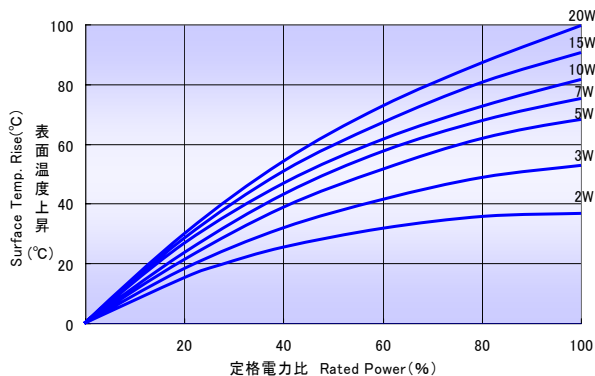

R□B-N

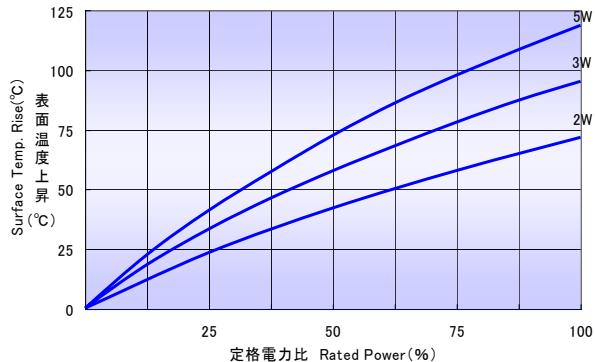

シャーシ固定放熱タイプ

●TYPE H

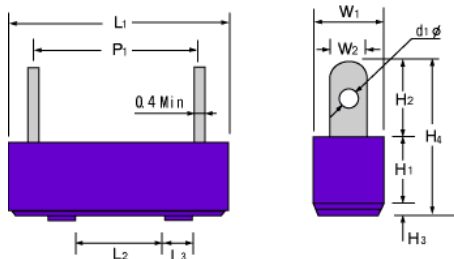

●TYPE HS

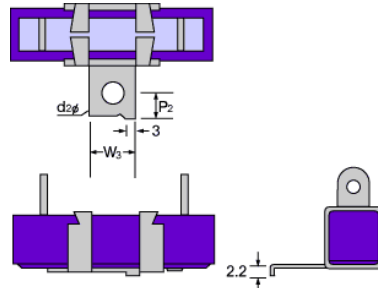

●TYPE HU

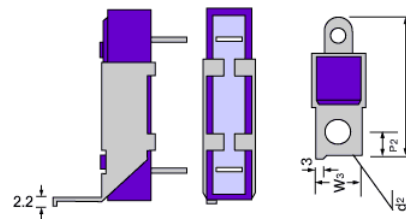

□寸法および定格 DIMENSIONS & RATING

形名 Type	定格電力 Power Rating	寸法 Dimensions(mm)				抵抗値範囲 Res.Range(Ω)		許容差 Tolerance
		L±1.5	W±1	H±1	C	RWB-G	RSB-G	
RWBG2, RSBG2	2W	18	6.3	7.9	1.5	10m~300	330~20K	±5% (J)
RWBG3, RSBG3	3W	22	8.0	9.8	1.5	10m~470	510~39K	
RWBG5, RSBG5	5W	22	9.5	11.0	1.5	10m~470	510~51K	
RWBG7, RSBG7	7W	35	9.5	12.5	3	0.1~470	510~100K	±10% (K)
RWBG10, RSBG10	10W	48	9.5	12.5	3	0.1~1K	1.1K~150K	

形名 Type	定格電力 Power Rating	寸法 dimensions(mm)				抵抗値範囲 Res.Range(Ω)		許容差 Tolerance
		W±1	H±1.5	D±1	C	RWB-N	RSB-N	
RWBN2, RSBN2	2W	11	20.5	7	2	10m~300	330~20K	±5%(J) ±10%(K)
RWBN3, RSBN3	3W	12	25.0	8	2	10m~470	510~39K	
RWBN5, RSBN5	5W	13	25.5	9	2	10m~470	510~51K	
RWBN7, RSBN7	7W	13	38.5	9	2.5	0.1~470	510~100K	
RWBN10, RSBN10	10W	16	35.0	12	2.5	0.1~1K	1.1K~150K	

形名 Type	定格電力 Power Rating	寸法 Dimensions(mm)														抵抗値範囲(Ω) Res.Range	
		L1	P1	L2	L3	W1	W2	H1	H2	H3	H4	d1 φ	d2 φ	P2	P3		W3±0.2
RWBH(-)10	10W	48±1.5	36 ⁺⁰ ₋₂	25±1	4.5	9.5±1	5	9.5±1	6 ^{+1.5} ₋₀	0.8	17 ^{+1.5} _{-1.0}	2	4	6	24.5 ⁺² ₋₁	12	1~1.8K
RWBH(-)15	15W	48±1.5	34 ⁺⁰ ₋₂	25±1	7	12.5±1.2	6	12.5±1.2	8 ⁺² ₋₀	1.0	21 ⁺² ₋₁	2.5	4	6	28 ^{+2.5} ₋₁	12	1~1.8K
RWBH(-)20	20W	63.5±2	50 ⁺⁰ ₋₃	25±1	7	12.5±1.2	6	12.5±1.2	8 ⁺² ₋₀	1.0	21 ⁺² ₋₁	2.5	4	6	28 ^{+2.5} ₋₁	12	1~2.7K
RWBH(-)30	30W	75±2.5	56 ⁺⁰ ₋₄	40±1.2	10	19±1.5	7.5	19±1.5	10 ⁺² ₋₀	1.0	30 ^{+2.5} _{-1.5}	3	4.2	8	39 ⁺³ _{-1.5}	18	1.5~4.5K
RWBH(-)40	40W	90±2.5	71 ⁺⁰ ₋₄	40±1.2	10	19±1.5	7.5	19±1.5	10 ⁺² ₋₀	1.0	30 ^{+2.5} _{-1.5}	3	4.2	8	39 ⁺³ _{-1.5}	18	1.8~5.5K

□品名の構成 CONSTRUCTION OF ITEM NAME

RWB	S	5	J	100 Ω
セメント抵抗器 RWB or RSB	形状 Style	定格電力 Power rated	抵抗値許容差 Resistance tolerance	抵抗値 Resistance