

巻線多回転形ポテンシヨメーター
Wire-Wound Multi-turn Potentiometer

RRS series

■ 設定用多回転(3. 5. 10回転)
ポテンシヨメーター

■ Multi-turn(3. 5. 10turns)
Potentiometer



■ 電氣的、機械的特性 Electrical and mechanical specifications

項目 Item	RRS 3	RRS 5	RRS 10
定格電力 Power ratings	0.3 W	0.5 W	1 W
抵抗値範囲 Resistance range	50 Ω ~ 20K Ω	50 Ω ~ 50K Ω	100 Ω ~ 100K Ω
抵抗値許容差 Resistance tolerance	±5%		
最高使用電圧 Maximum operating voltage	DC250V		
単独直進性 Independent linearity	規格一覧表による See the specification chart		
分解度 Resolution	規格一覧表による See the specification chart		
残留抵抗値 Residual resistance	0.5% max.		
等価雑音抵抗 Equivalent noise resistance	100 Ω max.		
絶縁抵抗 Insulation resistance	DC500V 100M Ω min.		
絶縁耐圧 Dielectric strength	AC750V for 1 minute		
電氣的回転角 Electrical angle nominal	1080°	1800°	3600°
機械的回転角 Mechanical angle nominal	1080° 3回転 3 turns	1800° 5回転 5 turns	3600° 10回転 10 turns
回転トルク Rotation torque	9.8×10 ⁻³ N・m (100g-cm) max.		
回転止強度 Stopper strength	3.9×10 ⁻¹ N・m (4Kg-cm) min.		
重量 Weight	13g	18g	25g

■ 環境特性 Environmental specifications

動作温度範囲 Operating temperature range	-55°C ~ 125°C
抵抗温度係数 Resistance temperature coefficient	100ppm max.

■規格 Spec.

●形状・寸法 Configuration(m/m)

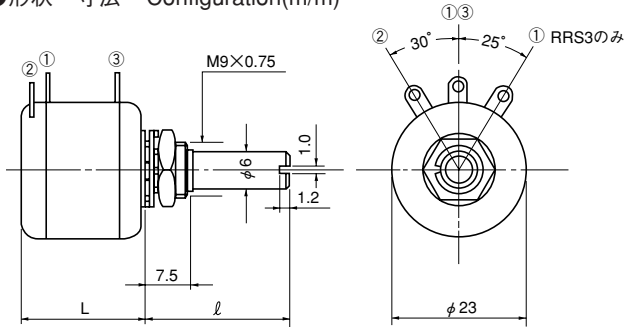

形状 Shape	L寸法 Dimensions(m/m)
RRS 3	11.4
RRS 5	14.8
RRS 10	21.5

シャフト Shaft	ℓ寸法 Dimensions(m/m)
M	21
S	16

シャフトM typeが標準品です。Shaft M type is a standard model.

●仕様 Specifications

抵抗値(Ω) Resistance	直線性 Linearity (%)			分解度 Resolution (%)		
	RRS 3	RRS 5	RRS 10	RRS 3	RRS 5	RRS 10
50	0.45	0.40	—	0.14	0.09	—
100	0.40	0.40	0.35	0.12	0.08	0.05
200	0.35	0.35	0.35	0.11	0.07	0.04
500	0.35	0.35	0.30	0.08	0.06	0.04
1K	0.30	0.30	0.30	0.07	0.05	0.03
2K	0.30	0.30	0.30	0.05	0.04	0.03
5K	0.30	0.30	0.25	0.04	0.025	0.025
10K	0.25	0.25	0.25	0.03	0.025	0.020
20K	0.25	0.25	0.25	0.02	0.020	0.011
50K	—	0.25	0.25	—	0.015	0.008
100K	—	—	0.25	—	—	0.007

●端子配線図

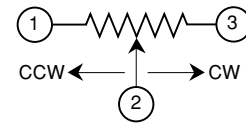

●定格電力軽減曲線 Derating Curve

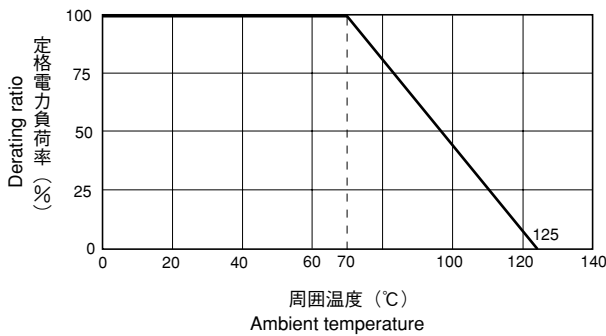

■標準抵抗値 (Ω) Standard resistance values

()内 抵抗値コード Resistance code

抵抗値(Ω)	50	100	200	500	1K	2K	5K	10K	20K	50K	100K
(抵抗値コード)	(500)	(101)	(201)	(501)	(102)	(202)	(502)	(103)	(203)	(503)	(104)

■在庫販売品 Available in stock

RRS3M type (50Ω~20KΩ)	RRS5M type (50Ω~50KΩ)	RRS10M type (100Ω~100KΩ)
--------------------------	--------------------------	-----------------------------

■品番コード Explanation of Part Number

RRS 10 M 102

抵抗値コード Resistance code (e.g. 1KΩ)

軸寸法 Shaft (M・S)

タイプ Type (3, 5, 10回転 turns)

品番 Part No.