

OPA445

High Voltage FET-Input OPERATIONAL AMPLIFIER

FEATURES

- WIDE POWER SUPPLY RANGE: $\pm 10V$ to $\pm 45V$
- HIGH SLEW RATE: $10V/\mu s$
- LOW INPUT BIAS CURRENT: 50pA max
- STANDARD-PINOUT TO-99 AND DIP PACKAGES

APPLICATIONS

- TEST EQUIPMENT
- HIGH VOLTAGE REGULATORS
- POWER AMPLIFIERS
- DATA ACQUISITION
- SIGNAL CONDITIONING

DESCRIPTION

The OPA445 is a monolithic operational amplifier capable of operation from power supplies up to $\pm 45V$ and output currents of 15mA. It is useful in a wide variety of applications requiring high output voltage or large common-mode voltage swings.

The OPA445's high slew rate provides wide power-bandwidth response, which is often required for high voltage applications. FET input circuitry allows the

use of high impedance feedback networks, thus minimizing their output loading effects. Laser trimming of the input circuitry yields low input offset voltage and drift.

The OPA445 is unity-gain stable and requires no external compensation components. It is available in both industrial ($-25^{\circ}C$ to $+85^{\circ}C$) and military ($-55^{\circ}C$ to $+125^{\circ}C$) temperature ranges.

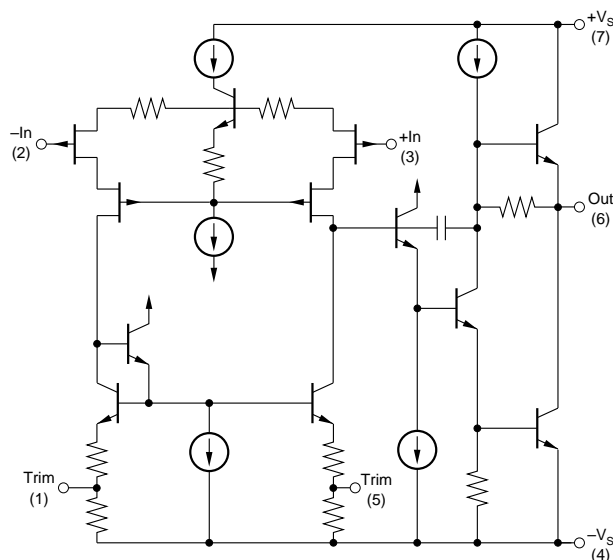

International Airport Industrial Park • Mailing Address: PO Box 11400 • Tucson, AZ 85734 • Street Address: 6730 S. Tucson Blvd. • Tucson, AZ 85706
Tel: (520) 746-1111 • Twx: 910-952-1111 • Cable: BBRCORP • Telex: 066-6491 • FAX: (520) 889-1510 • Immediate Product Info: (800) 548-6132

SPECIFICATIONS

ELECTRICAL

At $V_S = \pm 40^\circ\text{C}$ and $T_A = +25^\circ\text{C}$, unless otherwise specified.

PARAMETER	CONDITIONS	OPA445SM			OPA445BM			OPA445AP			UNITS
		MIN	TYP	MAX	MIN	TYP	MAX	MIN	TYP	MAX	
INPUT											
OFFSET VOLTAGE											
Input Offset Voltage	$V_{CM} = 0V$		0.5	1.0		1.0	3.0		2.0	5.0	mV
Average Drift	$T_A = T_{MIN}$ to T_{MAX}		*			10			15		$\mu\text{V}/^\circ\text{C}$
Supply Rejection	$V_S = \pm 10V$ to $\pm 50V$	*	*		80	110		*	*		dB
BIAS CURRENT											
Input Bias Current	$V_{CM} = 0V$		*	*		20	50		50	100	pA
Over Temperature				100		10				20	nA
OFFSET CURRENT											
Input Offset Current	$V_{CM} = 0V$		*	*		4	10		20	40	pA
Over Temperature				50		5			10		nA
IMPEDANCE											
Differential			*			$10^{13} \parallel 1$			*		$\Omega \parallel \text{pF}$
Common-Mode			*			$10^{14} \parallel 3$			*		$\Omega \parallel \text{pF}$
VOLTAGE RANGE											
Common-Mode Input Range		*			± 35			*			V
Common-Mode Rejection	$V_{IN} = \pm 30V$, Over Temp.	*	*		80	95		*	*		dB
OPEN-LOOP GAIN, DC											
Open-Loop Voltage Gain	$R_L = 5k\Omega$	*	*		100	105		*	*		dB
Over Temperature		*			97			*			dB
FREQUENCY RESPONSE											
Gain Bandwidth	Small Signal		*			2			*		MHz
Full Power Response	$35V_{p-p}$, $R_L = 5k\Omega$	*	*		45	55		*	*		kHz
DYNAMIC RESPONSE											
Slew Rate	$V_O = \pm 35V$, $R_L = 5k\Omega$	*	*		5	10		*	*		V/ μs
Rise Time	$V_O = \pm 200mV$		*			100			*		ns
Overshoot	$A_V = +1$ $Z_L = 5k\Omega \parallel 50pF$		*			30			*		%
OUTPUT											
Voltage Output, Over Temp.	$R_L = 5k\Omega$	*			± 35			*			V
Current Output	$V_O = \pm 28V$	*			± 15			*			mA
Output Resistance	DC, Open Loop		*			220			*		Ω
Short Circuit Current			*			± 26			*		mA
POWER SUPPLY											
Rated Voltage, $\pm V_S$			*			± 40			*		V
Voltage Range, $\pm V_S$											
Derated Performance	Over Temperature	*	*		± 10		± 45	*	*		V
Current, Quiescent	$I_O = 0mA$		*	*		3.8	4.5		*	*	mA
TEMPERATURE RANGE											
Specification		-55		+125	-25		+85	*		*	$^\circ\text{C}$
Operating	Ambient Temperature	*		*	-55		+125	-25		+85	$^\circ\text{C}$
θ Junction-Ambient			*			200			100		$^\circ\text{C}/W$

*Specifications same as OPA445BM.

CONNECTION DIAGRAMS

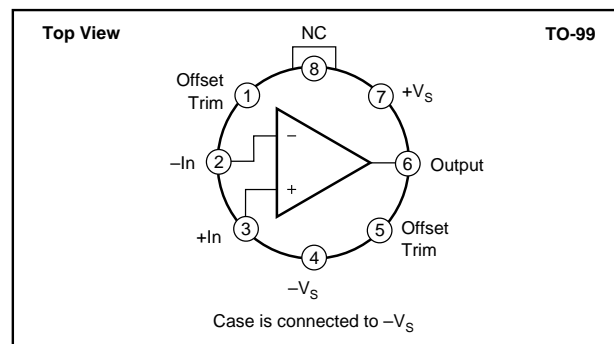
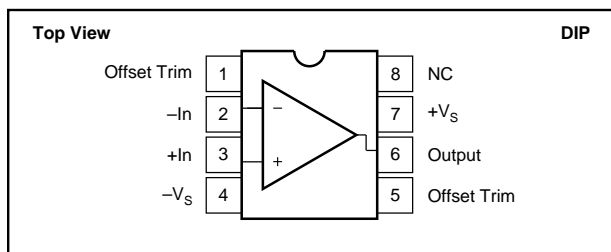

DICE INFORMATION

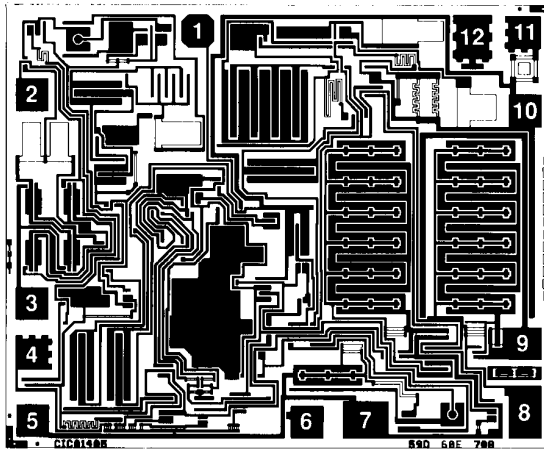

OPA445 DIE TOPOGRAPHY

PAD	FUNCTION	PAD	FUNCTION
1	Offset Trim	7	$-V_S$
2	$-In$	8	(Compensation)
3	$+In$	9	Output
4	NC	10	$+V_S$
5	$-V_S$	11	NC
6	Offset Trim	12	NC

Substrate Bias: Electrically connected to $-V_S$ supply.
 NC: No Connection.

MECHANICAL INFORMATION

	MILS (0.001")	MILLIMETERS
Die Size	88 x 72 ±5	2.24 x 1.83 ±0.13
Die Thickness	20 ±3	0.51 ±0.08
Min. Pad Size	4 x 4	0.1 x 0.1
Backing	Chromium-Silver	

ABSOLUTE MAXIMUM RATINGS

Power Supply	±50V
Internal Power Dissipation	680mW
Differential Input Voltage	±80V
Input Voltage Range	$ \pm V_S - 3V$
Storage Temperature Range: M	-65°C to +150°C
P	-40°C to +85°C
Operating Temperature Range: M	-55°C to +125°C
P	-40°C to +85°C
Lead Temperature (soldering, 10s)	+300°C
Output Short-Circuit to Ground ($T_A = +25^\circ C$)	Continuous
Junction Temperature	+175°C

ORDERING INFORMATION

MODEL	PACKAGE	TEMPERATURE RANGE
OPA445AP	8-pin plastic DIP	-25°C to +85°C
OPA445BM	8-pin TO-99	-25°C to +85°C
OPA445SM	8-pin TO-99	-55°C to +125°C

PACKAGE INFORMATION

MODEL	PACKAGE	PACKAGE DRAWING NUMBER ⁽¹⁾
OPA445AP	8-pin plastic DIP	006
OPA445BM	8-pin TO-99	001
OPA445SM	8-pin TO-99	001

NOTE: (1) For detailed drawing and dimension table, please see end of data sheet, or Appendix D of Burr-Brown IC Data Book.

TYPICAL PERFORMANCE CURVES

$T_A = +25^\circ C$, $V_S = \pm 40VDC$, unless otherwise noted.

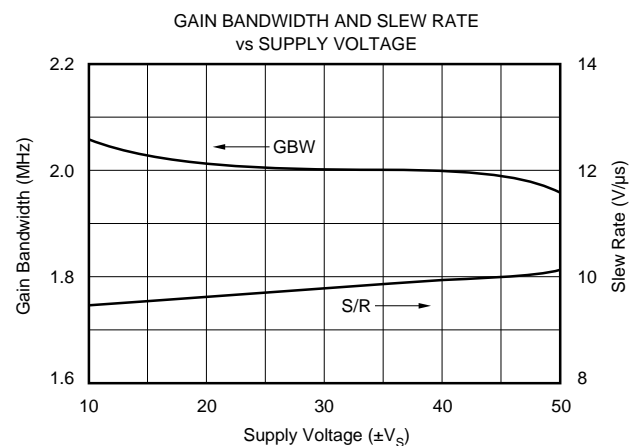
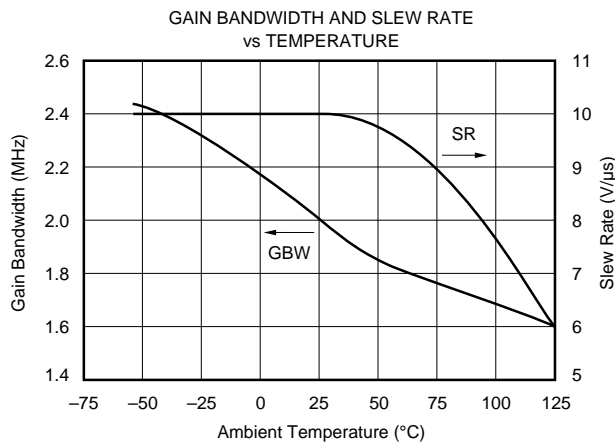

TYPICAL PERFORMANCE CURVES (CONT)

$T_A = +25^\circ\text{C}$, $V_S = \pm 40\text{VDC}$, unless otherwise noted.

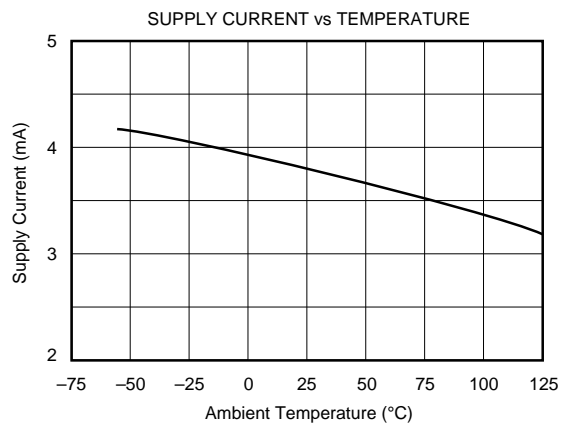
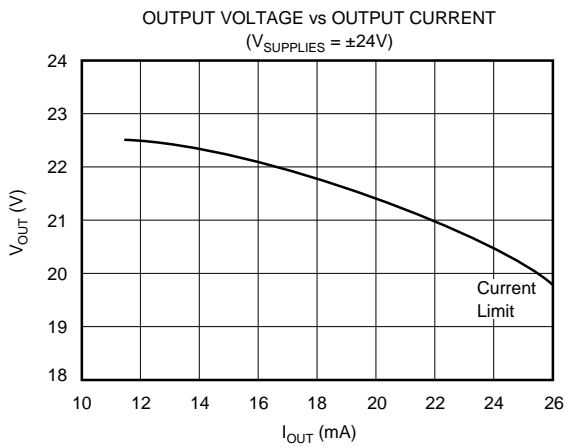
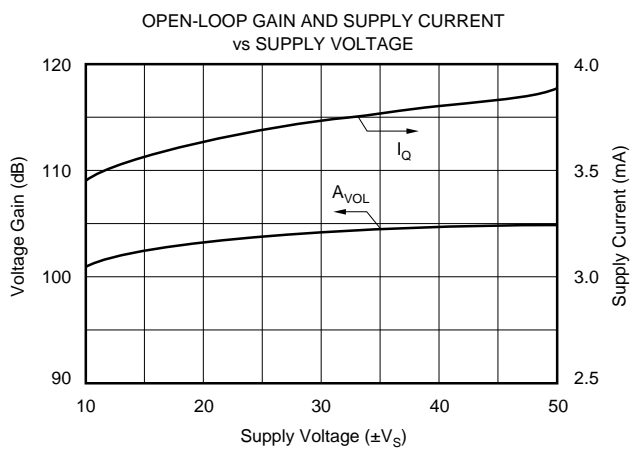
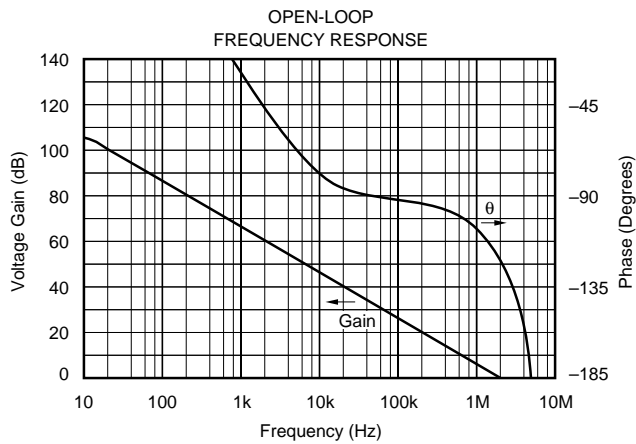
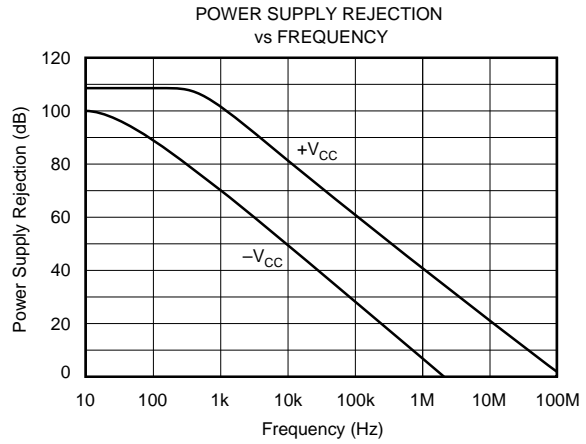
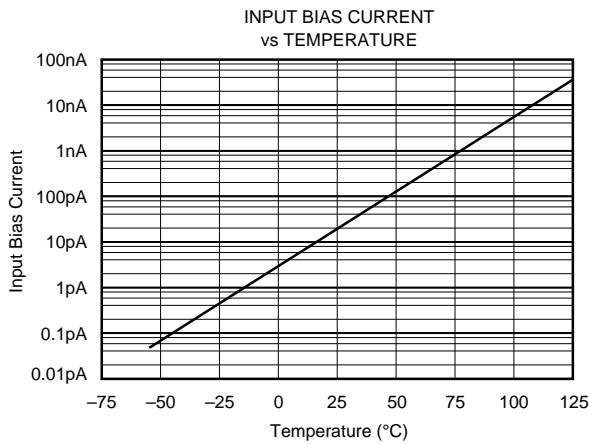

TYPICAL PERFORMANCE CURVES (CONT)

$T_A = +25^\circ\text{C}$, $V_S = \pm 15\text{VDC}$ unless otherwise noted.

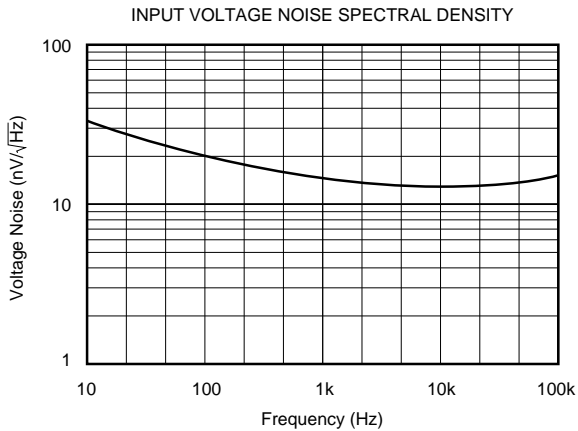
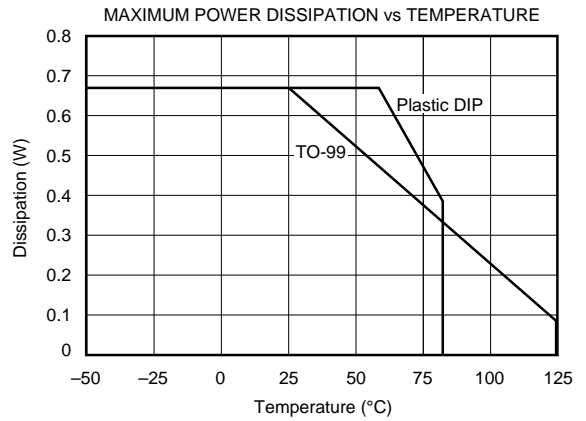
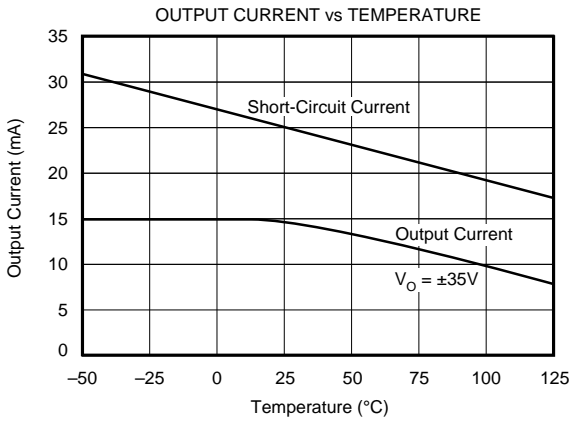
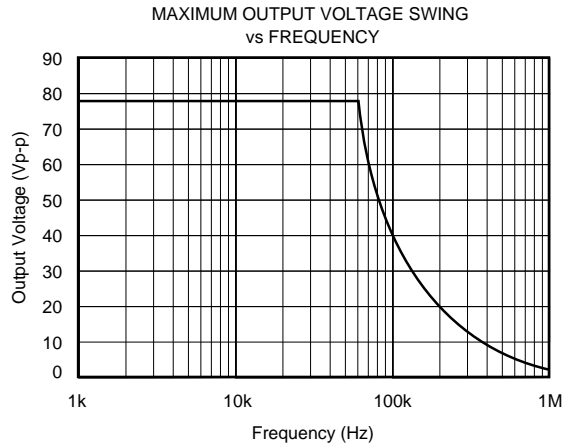
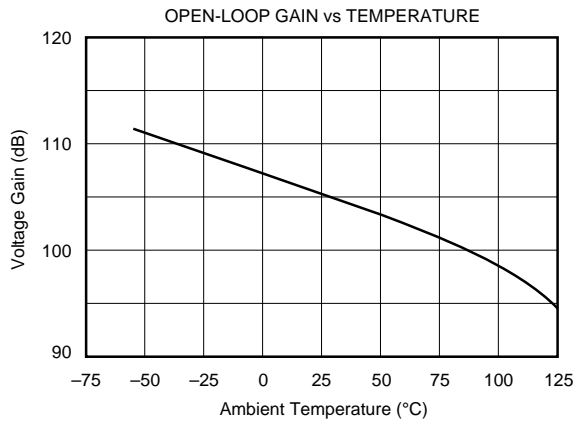

The information provided herein is believed to be reliable; however, BURR-BROWN assumes no responsibility for inaccuracies or omissions. BURR-BROWN assumes no responsibility for the use of this information, and all use of such information shall be entirely at the user's own risk. Prices and specifications are subject to change without notice. No patent rights or licenses to any of the circuits described herein are implied or granted to any third party. BURR-BROWN does not authorize or warrant any BURR-BROWN product for use in life support devices and/or systems.

INSTALLATION AND OPERATING INSTRUCTIONS

The OPA445 may be operated from power supplies up to $\pm 45V$ or a total of 90V. Power supplies should be bypassed with 0.022 μF capacitors, or greater, near the power supply pins. Be sure that the capacitors are appropriately rated for the supply voltage used.

The OPA445 can supply output currents of 15mA and larger. This would present no problem for a standard op amp operating from $\pm 15V$ supplies. With high supply voltages, however, internal power dissipation of the op amp can be quite large. Operation from a single power supply (or unbalanced power supplies) can produce even larger power dissipation since a larger voltage is impressed across the conducting output transistor.

Dissipation should be limited to 680mW at 25°C. At temperatures above 25°C, the maximum dissipation should be derated according to the thermal resistance of the package type used.

Package thermal resistance, θ_{JC} , is affected by mounting techniques and environments. The figures provided are typical for common mounting configurations with convection air flow. Poor air circulation and use of sockets can significantly increase thermal resistance. Best thermal performance is achieved by soldering the op amp into a circuit board with wide printed circuit traces to allow greater conduction through the op amp leads. Simple clip-on heat sinks can reduce the thermal resistance of the TO-99 metal package by as much as 50°C/W.

A short-circuit to ground will produce a typical output current of 25mA. With $\pm 40V$ power supplies, this creates an internal power dissipation of 1.0W. This exceeds the maximum rating for the device, and is not recommended. Permanent damage is unlikely, however, since the short-circuit output current will diminish as the junction temperature rises.

TYPICAL APPLICATIONS

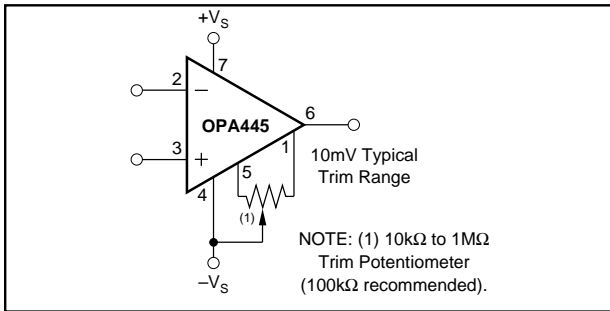

FIGURE 1. Offset Voltage Trim.

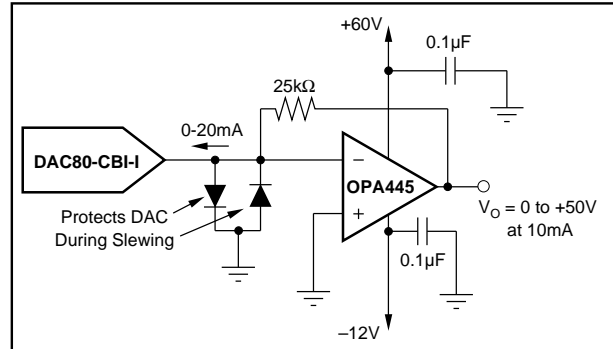

FIGURE 3. Programmable Voltage Source.

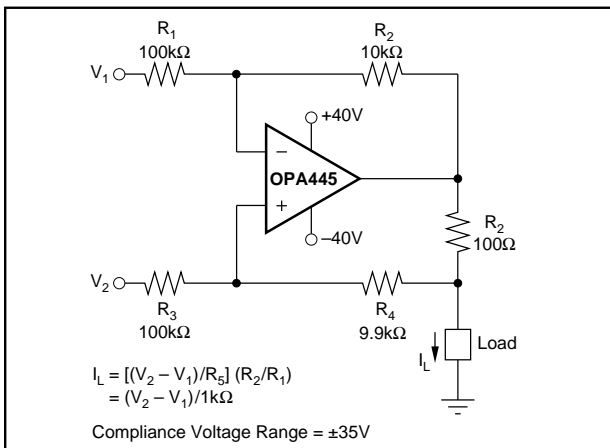

FIGURE 2. Voltage-to-Current Converter.