

LF155/LF156/LF256/LF257/LF355/LF356/LF357

JFET Input Operational Amplifiers

General Description

These are the first monolithic JFET input operational amplifiers to incorporate well matched, high voltage JFETs on the same chip with standard bipolar transistors (BI-FET™ Technology). These amplifiers feature low input bias and offset currents/low offset voltage and offset voltage drift, coupled with offset adjust which does not degrade drift or common-mode rejection. The devices are also designed for high slew rate, wide bandwidth, extremely fast settling time, low voltage and current noise and a low 1/f noise corner.

Features

Advantages

- Replace expensive hybrid and module FET op amps
- Rugged JFETs allow blow-out free handling compared with MOSFET input devices
- Excellent for low noise applications using either high or low source impedance—very low 1/f corner
- Offset adjust does not degrade drift or common-mode rejection as in most monolithic amplifiers
- New output stage allows use of large capacitive loads (5,000 pF) without stability problems
- Internal compensation and large differential input voltage capability

Applications

- Precision high speed integrators
- Fast D/A and A/D converters
- High impedance buffers
- Wideband, low noise, low drift amplifiers

- Logarithmic amplifiers
- Photocell amplifiers
- Sample and Hold circuits

Common Features

- Low input bias current: 30pA
- Low Input Offset Current: 3pA
- High input impedance: $10^{12}\Omega$
- Low input noise current: $0.01 \text{ pA}/\sqrt{\text{Hz}}$
- High common-mode rejection ratio: 100 dB
- Large dc voltage gain: 106 dB

Uncommon Features

	LF155/ LF355	LF156/ LF256/ LF356	LF257/ LF357 ($A_V=5$)	Units
■ Extremely fast settling time to 0.01%	4	1.5	1.5	μs
■ Fast slew rate	5	12	50	$\text{V}/\mu\text{s}$
■ Wide gain bandwidth	2.5	5	20	MHz
■ Low input noise voltage	20	12	12	$\text{nV}/\sqrt{\text{Hz}}$

Simplified Schematic

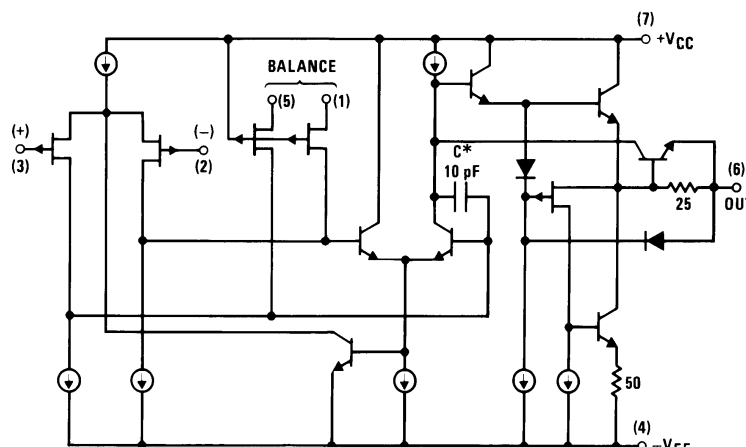

*3pF in LF357 series.

00564601

BI-FET™, BI-FET II™ are trademarks of National Semiconductor Corporation.

Absolute Maximum Ratings (Note 1)

If Military/Aerospace specified devices are required, contact the National Semiconductor Sales Office/Distributors for availability and specifications.

	LF155/6	LF256/7/LF356B	LF355/6/7
Supply Voltage	±22V	±22V	±18V
Differential Input Voltage	±40V	±40V	±30V
Input Voltage Range (Note 2)	±20V	±20V	±16V
Output Short Circuit Duration	Continuous	Continuous	Continuous
T_{JMAX}			
H-Package	150°C	115°C	115°C
N-Package		100°C	100°C
M-Package		100°C	100°C
Power Dissipation at $T_A = 25^\circ\text{C}$ (Notes 1, 8)			
H-Package (Still Air)	560 mW	400 mW	400 mW
H-Package (400 LF/Min Air Flow)	1200 mW	1000 mW	1000 mW
N-Package		670 mW	670 mW
M-Package		380 mW	380 mW
Thermal Resistance (Typical) θ_{JA}			
H-Package (Still Air)	160°C/W	160°C/W	160°C/W
H-Package (400 LF/Min Air Flow)	65°C/W	65°C/W	65°C/W
N-Package		130°C/W	130°C/W
M-Package		195°C/W	195°C/W
(Typical) θ_{JC}			
H-Package	23°C/W	23°C/W	23°C/W
Storage Temperature Range	-65°C to +150°C	-65°C to +150°C	-65°C to +150°C
Soldering Information (Lead Temp.)			
Metal Can Package			
Soldering (10 sec.)	300°C	300°C	300°C
Dual-In-Line Package			
Soldering (10 sec.)	260°C	260°C	260°C
Small Outline Package			
Vapor Phase (60 sec.)		215°C	215°C
Infrared (15 sec.)		220°C	220°C
See AN-450 "Surface Mounting Methods and Their Effect on Product Reliability" for other methods of soldering surface mount devices.			
ESD tolerance			
(100 pF discharged through 1.5k Ω)	1000V	1000V	1000V

DC Electrical Characteristics

(Note 3)

Symbol	Parameter	Conditions	LF155/6			LF256/7 LF356B			LF355/6/7			Units
			Min	Typ	Max	Min	Typ	Max	Min	Typ	Max	
V_{OS}	Input Offset Voltage	$R_S=50\Omega$, $T_A=25^\circ\text{C}$ Over Temperature		3	5		3	5		3	10	mV
					7		6.5		13			mV
$\Delta V_{OS}/\Delta T$	Average TC of Input Offset Voltage	$R_S=50\Omega$		5			5			5	$\mu\text{V}/^\circ\text{C}$	
$\Delta\text{TC}/\Delta V_{OS}$	Change in Average TC with V_{OS} Adjust	$R_S=50\Omega$, (Note 4)		0.5			0.5			0.5	$\mu\text{V}/^\circ\text{C}$ per mV	
I_{OS}	Input Offset Current	$T_J=25^\circ\text{C}$, (Notes 3, 5) $T_J \leq T_{HIGH}$		3	20		3	20		3	50	pA
					20		1		2			nA

DC Electrical Characteristics (Continued)

(Note 3)

Symbol	Parameter	Conditions	LF155/6			LF256/7 LF356B			LF355/6/7			Units
			Min	Typ	Max	Min	Typ	Max	Min	Typ	Max	
I_B	Input Bias Current	$T_J=25^\circ\text{C}$, (Notes 3, 5) $T_J \leq T_{HIGH}$		30	100		30	100		30	200	pA nA
R_{IN}	Input Resistance	$T_J=25^\circ\text{C}$		10^{12}			10^{12}			10^{12}		Ω
A_{VOL}	Large Signal Voltage Gain	$V_S=\pm 15\text{V}$, $T_A=25^\circ\text{C}$ $V_O=\pm 10\text{V}$, $R_L=2\text{k}$ Over Temperature	50	200		50	200		25	200		V/mV V/mV
V_O	Output Voltage Swing	$V_S=\pm 15\text{V}$, $R_L=10\text{k}$ $V_S=\pm 15\text{V}$, $R_L=2\text{k}$	± 12	± 13		± 12	± 13		± 12	± 13		V V
V_{CM}	Input Common-Mode Voltage Range	$V_S=\pm 15\text{V}$	± 11	+15.1 -12		± 11	± 15.1 -12		+10	+15.1 -12		V V
CMRR	Common-Mode Rejection Ratio		85	100		85	100		80	100		dB
PSRR	Supply Voltage Rejection Ratio	(Note 6)	85	100		85	100		80	100		dB

DC Electrical Characteristics

$T_A = T_J = 25^\circ\text{C}$, $V_S = \pm 15\text{V}$

Parameter	LF155		LF355		LF156/256/257/356B		LF356		LF357		Units
	Typ	Max	Typ	Max	Typ	Max	Typ	Max	Typ	Max	
Supply Current	2	4	2	4	5	7	5	10	5	10	mA

AC Electrical Characteristics

$T_A = T_J = 25^\circ\text{C}$, $V_S = \pm 15\text{V}$

Symbol	Parameter	Conditions	LF155/355	LF156/256/ 356B	LF156/256/356/ LF356B	LF257/357	Units
			Typ	Min	Typ	Typ	
SR	Slew Rate	LF155/6: $A_V=1$, LF357: $A_V=5$	5	7.5	12		V/ μs V/ μs
GBW	Gain Bandwidth Product		2.5		5	20	MHz
t_s	Settling Time to 0.01%	(Note 7)	4		1.5	1.5	μs
e_n	Equivalent Input Noise Voltage	$R_S=100\Omega$ $f=100\text{ Hz}$ $f=1000\text{ Hz}$	25		15	15	nV/ $\sqrt{\text{Hz}}$ nV/ $\sqrt{\text{Hz}}$
i_n	Equivalent Input Current Noise	$f=100\text{ Hz}$ $f=1000\text{ Hz}$	0.01		0.01	0.01	pA/ $\sqrt{\text{Hz}}$ pA/ $\sqrt{\text{Hz}}$
C_{IN}	Input Capacitance		3		3	3	pF

Notes for Electrical Characteristics

Note 1: The maximum power dissipation for these devices must be derated at elevated temperatures and is dictated by T_{JMAX} , θ_{JA} , and the ambient temperature, T_A . The maximum available power dissipation at any temperature is $P_D=(T_{JMAX}-T_A)/\theta_{JA}$ or the 25°C P_{DMAX} , whichever is less.

Note 2: Unless otherwise specified the absolute maximum negative input voltage is equal to the negative power supply voltage.

Note 3: Unless otherwise stated, these test conditions apply:

Notes for Electrical Characteristics (Continued)

	LF155/156	LF256/257	LF356B	LF355/6/7
Supply Voltage, V_S	$\pm 15V \leq V_S \leq \pm 20V$	$\pm 15V \leq V_S \leq \pm 20V$	$\pm 15V \leq V_S \leq \pm 20V$	$V_S = \pm 15V$
T_A	$-55^\circ C \leq T_A \leq +125^\circ C$	$-25^\circ C \leq T_A \leq +85^\circ C$	$0^\circ C \leq T_A \leq +70^\circ C$	$0^\circ C \leq T_A \leq +70^\circ C$
T_{HIGH}	$+125^\circ C$	$+85^\circ C$	$+70^\circ C$	$+70^\circ C$

and V_{OS} , I_B and I_{OS} are measured at $V_{CM} = 0$.

Note 4: The Temperature Coefficient of the adjusted input offset voltage changes only a small amount ($0.5\mu V/^\circ C$ typically) for each mV of adjustment from its original unadjusted value. Common-mode rejection and open loop voltage gain are also unaffected by offset adjustment.

Note 5: The input bias currents are junction leakage currents which approximately double for every $10^\circ C$ increase in the junction temperature, T_J . Due to limited production test time, the input bias currents measured are correlated to junction temperature. In normal operation the junction temperature rises above the ambient temperature as a result of internal power dissipation, P_d . $T_J = T_A + \theta_{JA} P_d$ where θ_{JA} is the thermal resistance from junction to ambient. Use of a heat sink is recommended if input bias current is to be kept to a minimum.

Note 6: Supply Voltage Rejection is measured for both supply magnitudes increasing or decreasing simultaneously, in accordance with common practice.

Note 7: Settling time is defined here, for a unity gain inverter connection using $2k\Omega$ resistors for the LF155/6. It is the time required for the error voltage (the voltage at the inverting input pin on the amplifier) to settle to within 0.01% of its final value from the time a 10V step input is applied to the inverter. For the LF357, $A_V = -5$, the feedback resistor from output to input is $2k\Omega$ and the output step is 10V (See Settling Time Test Circuit).

Note 8: Max. Power Dissipation is defined by the package characteristics. Operating the part near the Max. Power Dissipation may cause the part to operate outside guaranteed limits.

Typical DC Performance Characteristics Curves are for LF155 and LF156 unless otherwise specified.

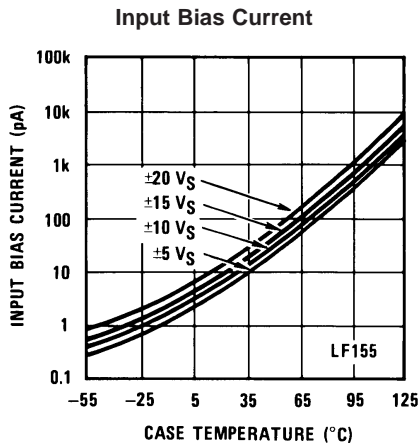

00564637

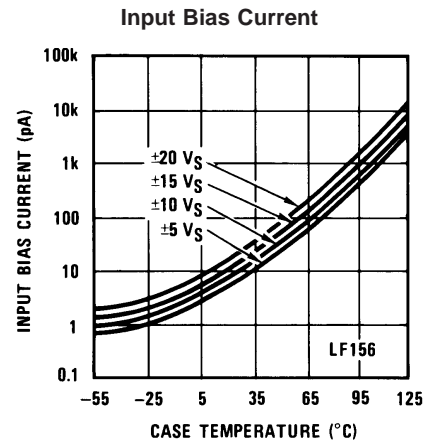

00564638

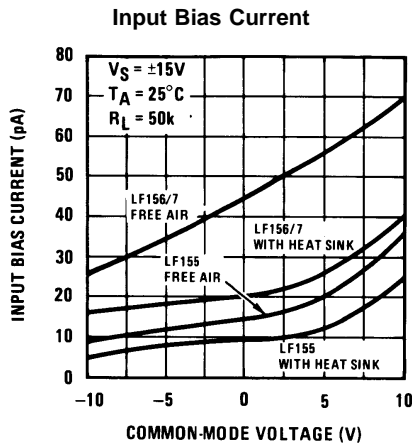

00564639

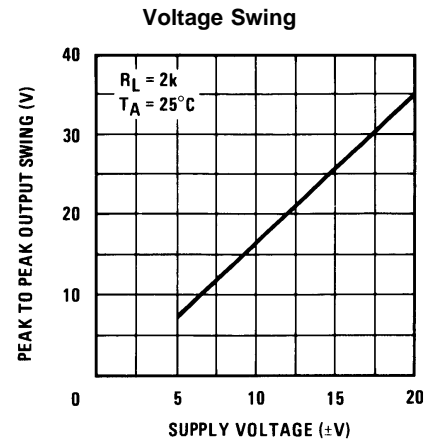

00564640

Typical DC Performance Characteristics

specified. (Continued)

Curves are for LF155 and LF156 unless otherwise specified.

Supply Current

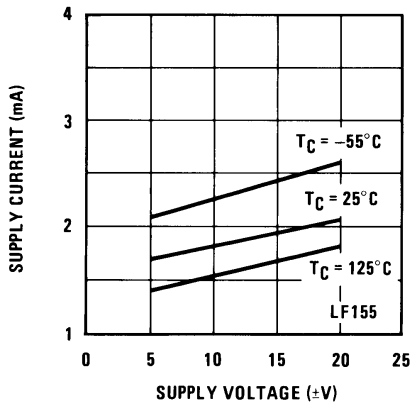

00564641

Supply Current

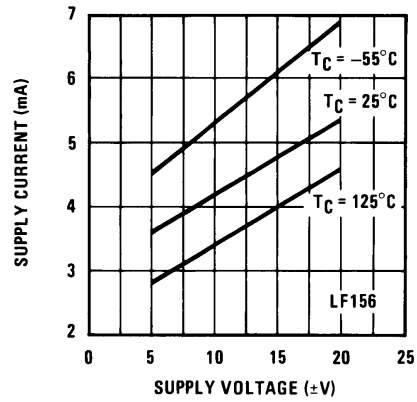

00564642

Negative Current Limit

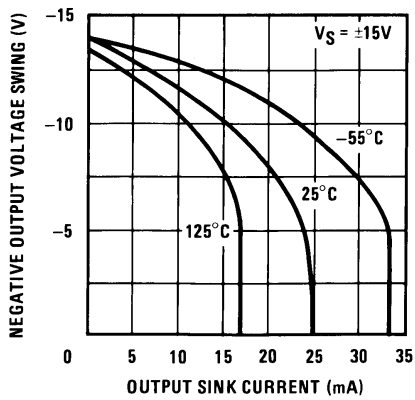

00564643

Positive Current Limit

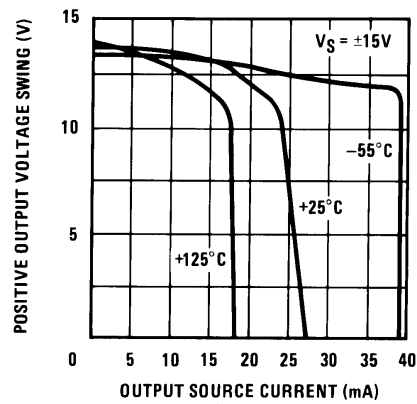

00564644

Positive Common-Mode Input Voltage Limit

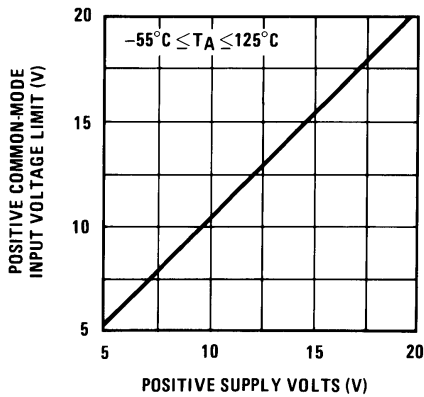

00564645

Negative Common-Mode Input Voltage Limit

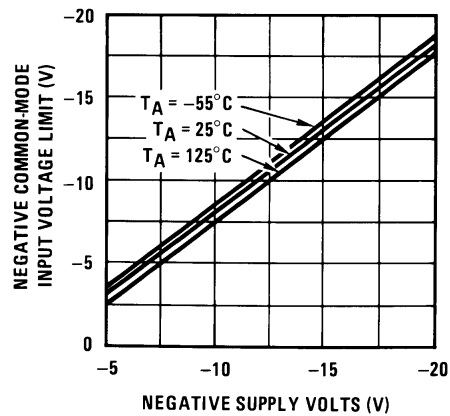

00564646

Typical DC Performance Characteristics

Curves are for LF155 and LF156 unless otherwise specified. (Continued)

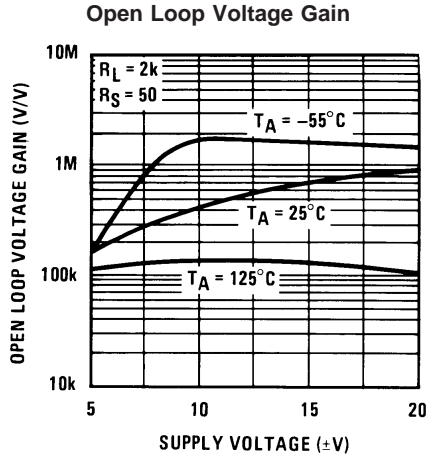

00564647

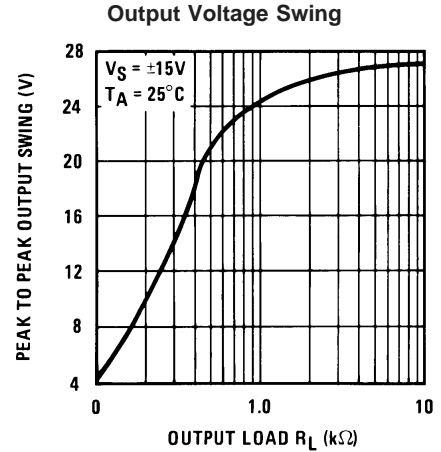

00564648

Typical AC Performance Characteristics

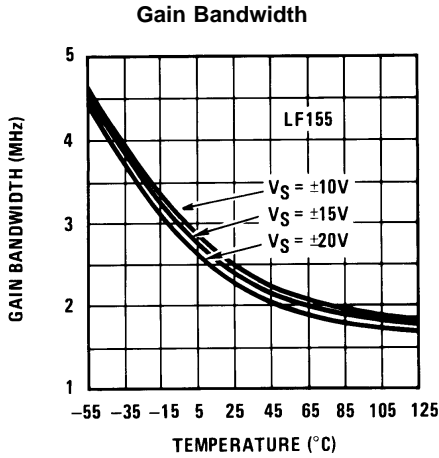

00564649

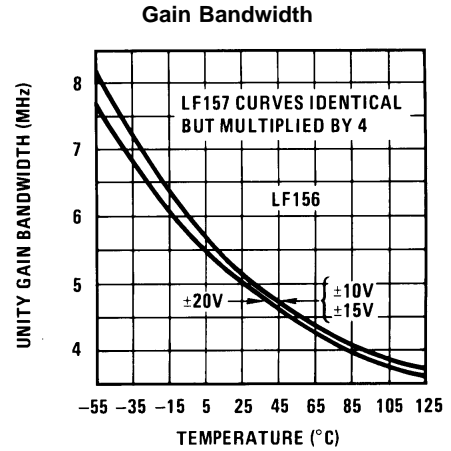

00564650

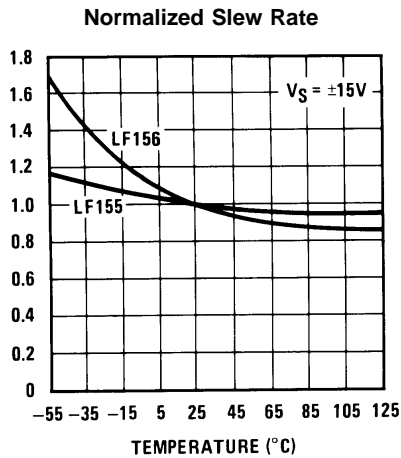

00564651

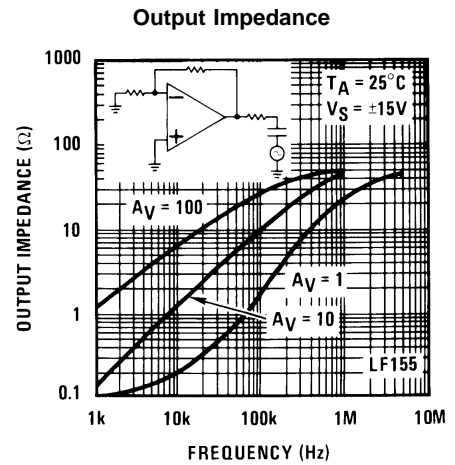

00564652

Typical AC Performance Characteristics (Continued)

Output Impedance

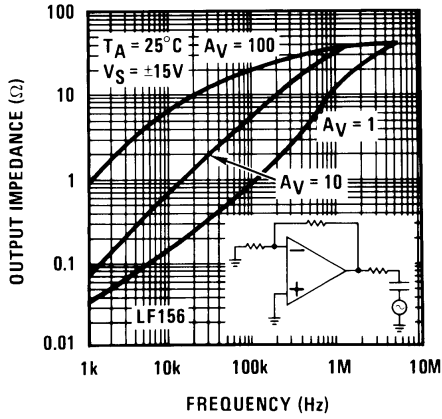

00564653

LF155 Small Signal Pulse Response, $A_V = +1$

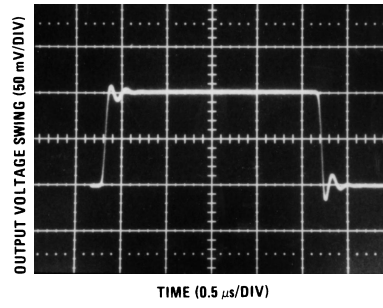

00564605

LF156 Small Signal Pulse Response, $A_V = +1$

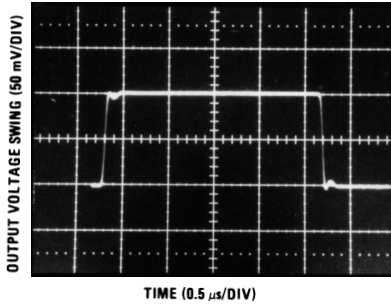

00564606

LF155 Large Signal Pulse Response, $A_V = +1$

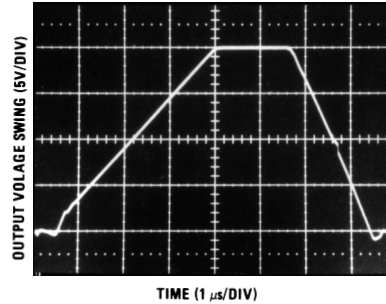

00564608

LF156 Large Signal Puls Response, $A_V = +1$

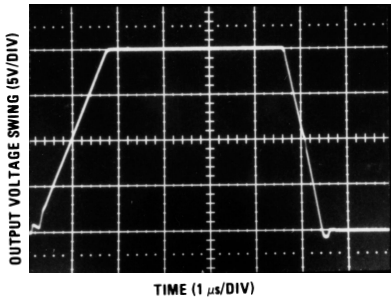

00564609

Inverter Settling Time

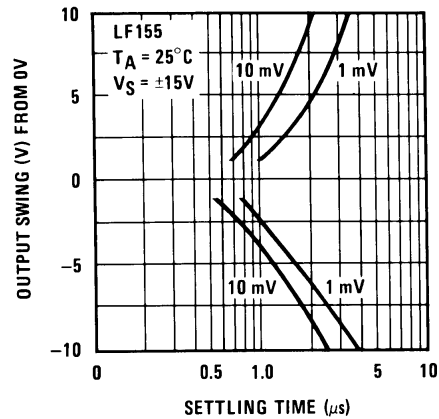

00564655

Typical AC Performance Characteristics (Continued)

Inverter Settling Time

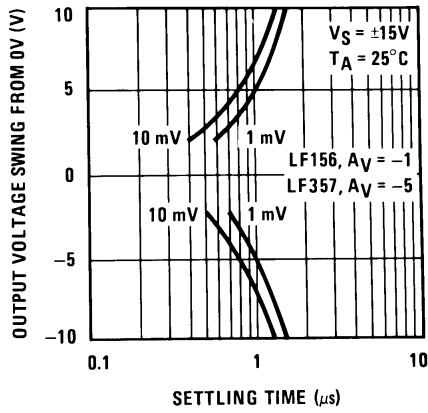

00564656

Open Loop Frequency Response

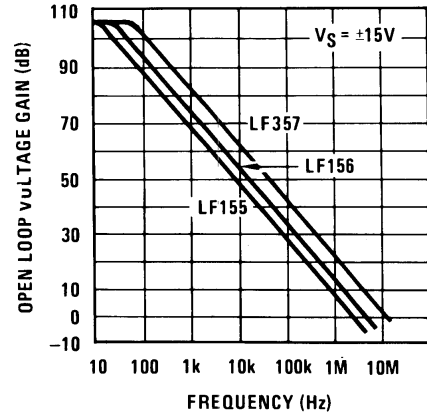

00564657

Bode Plot

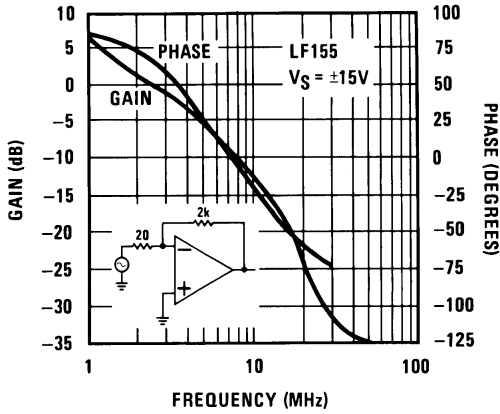

00564658

Bode Plot

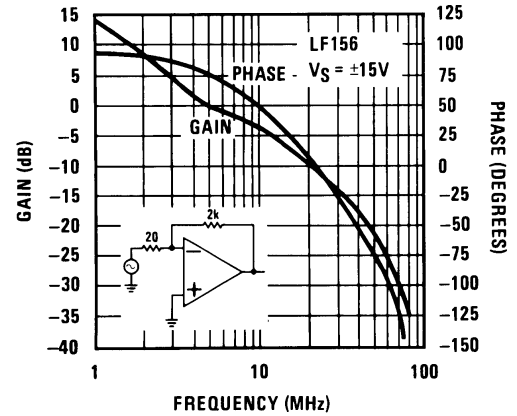

00564659

Bode Plot

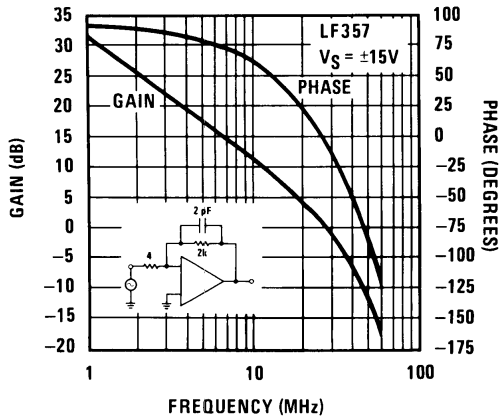

00564660

Common-Mode Rejection Ratio

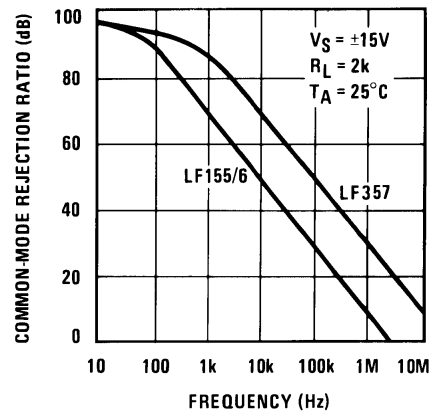

00564661

Typical AC Performance Characteristics (Continued)

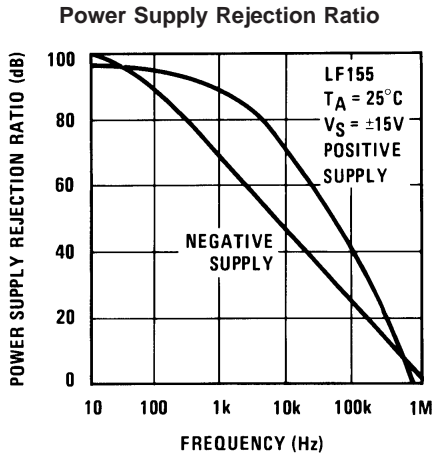

00564662

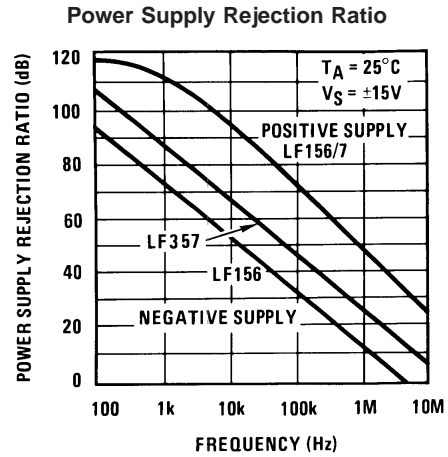

00564663

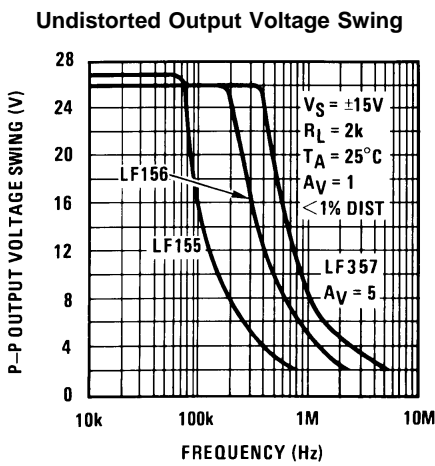

00564664

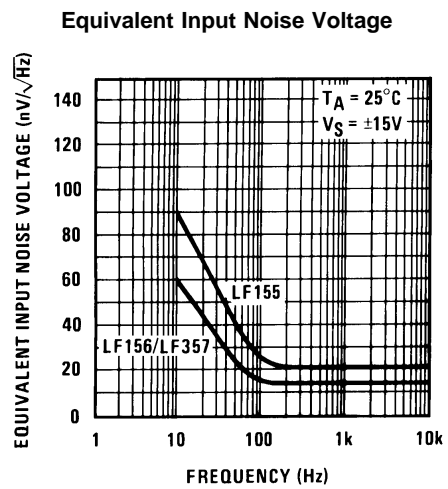

00564665

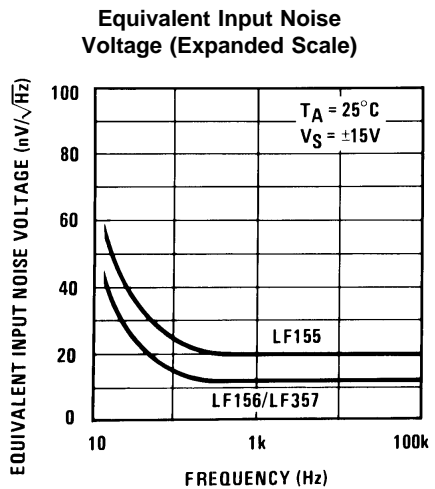

00564666

Detailed Schematic

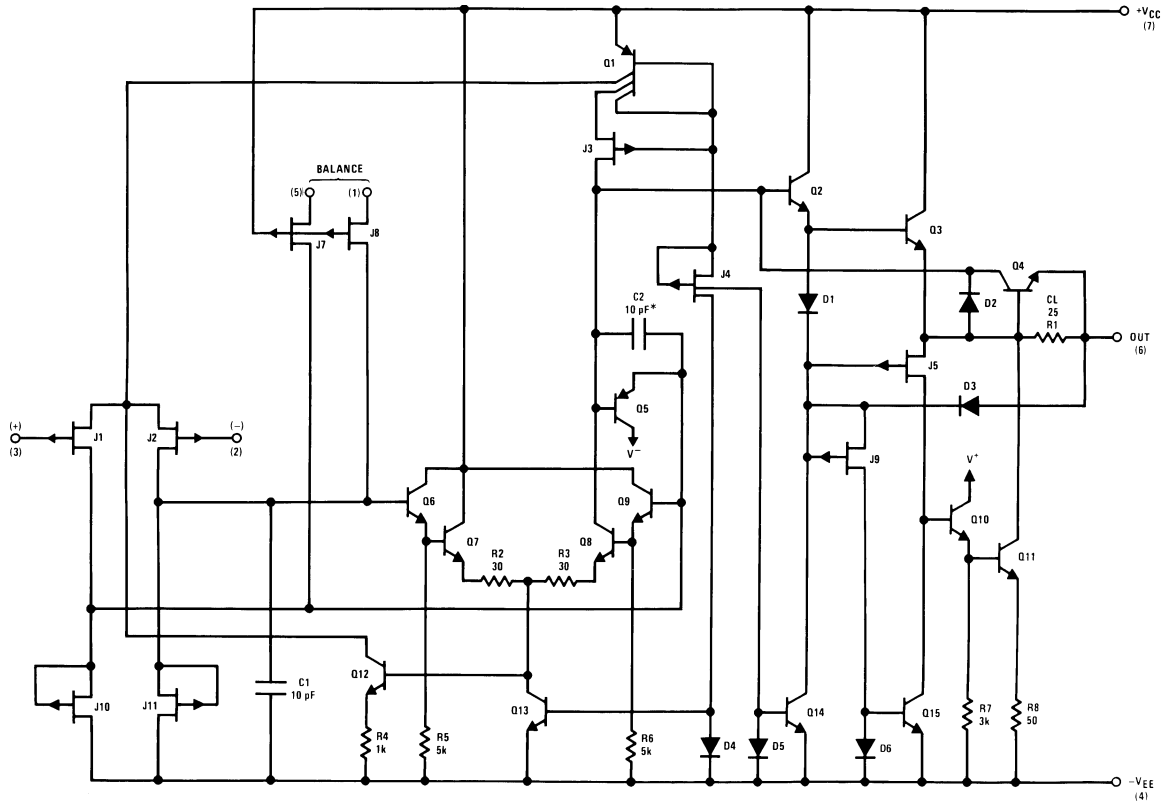

*C = 3pF in LF357 series.

00564613

Connection Diagrams (Top Views)

Metal Can Package (H)

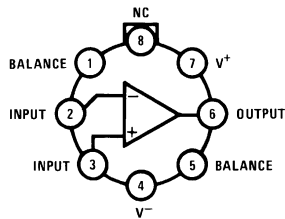

00564614

Order Number LF155H, LF156H, LF256H, LF257H,
LF356BH, LF356H, or LF357H
See NS Package Number H08C

*Available per JM38510/11401 or JM38510/11402

Dual-In-Line Package (M and N)

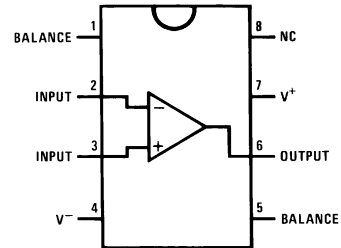

00564629

Order Number LF356M, LF356MX, LF355N, or LF356N
See NS Package Number M08A or N08E

Application Hints

These are op amps with JFET input devices. These JFETs have large reverse breakdown voltages from gate to source and drain eliminating the need for clamps across the inputs. Therefore large differential input voltages can easily be accommodated without a large increase in input current. The maximum differential input voltage is independent of the supply voltages. However, neither of the input voltages should be allowed to exceed the negative supply as this will cause large currents to flow which can result in a destroyed unit.

Exceeding the negative common-mode limit on either input will force the output to a high state, potentially causing a

Application Hints (Continued)

reversal of phase to the output. Exceeding the negative common-mode limit on both inputs will force the amplifier output to a high state. In neither case does a latch occur since raising the input back within the common-mode range again puts the input stage and thus the amplifier in a normal operating mode.

Exceeding the positive common-mode limit on a single input will not change the phase of the output however, if both inputs exceed the limit, the output of the amplifier will be forced to a high state.

These amplifiers will operate with the common-mode input voltage equal to the positive supply. In fact, the common-mode voltage can exceed the positive supply by approximately 100 mV independent of supply voltage and over the full operating temperature range. The positive supply can therefore be used as a reference on an input as, for example, in a supply current monitor and/or limiter.

Precautions should be taken to ensure that the power supply for the integrated circuit never becomes reversed in polarity or that the unit is not inadvertently installed backwards in a socket as an unlimited current surge through the resulting forward diode within the IC could cause fusing of the internal conductors and result in a destroyed unit.

All of the bias currents in these amplifiers are set by FET current sources. The drain currents for the amplifiers are therefore essentially independent of supply voltage.

As with most amplifiers, care should be taken with lead dress, component placement and supply decoupling in order to ensure stability. For example, resistors from the output to an input should be placed with the body close to the input to minimize "pickup" and maximize the frequency of the feedback pole by minimizing the capacitance from the input to ground.

A feedback pole is created when the feedback around any amplifier is resistive. The parallel resistance and capacitance from the input of the device (usually the inverting input) to AC ground set the frequency of the pole. In many instances the frequency of this pole is much greater than the expected 3dB frequency of the closed loop gain and consequently there is negligible effect on stability margin. However, if the feedback pole is less than approximately six times the expected 3 dB frequency a lead capacitor should be placed from the output to the input of the op amp. The value of the added capacitor should be such that the RC time constant of this capacitor and the resistance it parallels is greater than or equal to the original feedback pole time constant.

Typical Circuit Connections

V_{OS} Adjustment

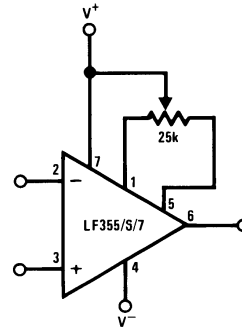

00564667

- V_{OS} is adjusted with a 25k potentiometer
- The potentiometer wiper is connected to V^+
- For potentiometers with temperature coefficient of 100 ppm/ $^{\circ}C$ or less the additional drift with adjust is $\approx 0.5\mu V/^{\circ}C$ of adjustment
- Typical overall drift: $5\mu V/^{\circ}C \pm (0.5\mu V/^{\circ}C/mV \text{ of adj.})$

Driving Capacitive Loads

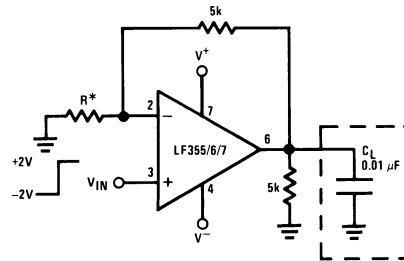

00564668

- * LF155/6 $R = 5k$
- LF357 $R = 1.25k$

Due to a unique output stage design, these amplifiers have the ability to drive large capacitive loads and still maintain stability. $C_{L(MAX)} \approx 0.01\mu F$.

Overshoot $\leq 20\%$

Settling time (t_s) $\approx 5\mu s$

LF357. A Large Power BW Amplifier

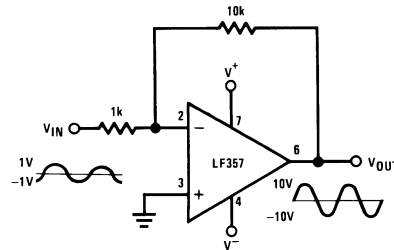

00564615

For distortion $\leq 1\%$ and a 20 Vp-p V_{OUT} swing, power bandwidth is: 500kHz.

Typical Applications

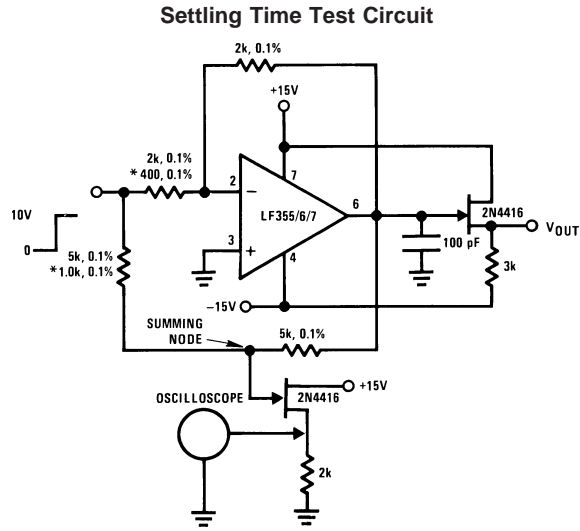

00564616

- Settling time is tested with the LF155/6 connected as unity gain inverter and LF357 connected for $A_V = -5$
- FET used to isolate the probe capacitance
- Output = 10V step
- $A_V = -5$ for LF357

Large Signal Inverter Output, V_{OUT} (from Settling Time Circuit)

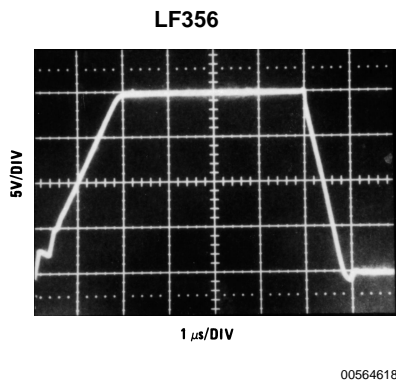
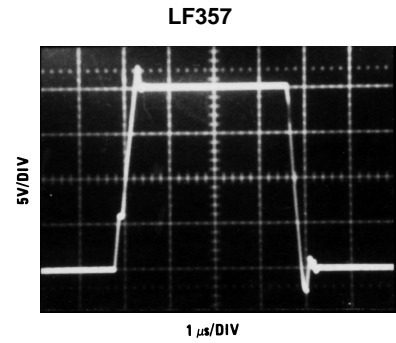
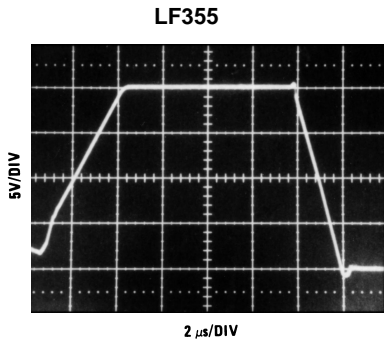

Typical Applications (Continued)

Low Drift Adjustable Voltage Reference

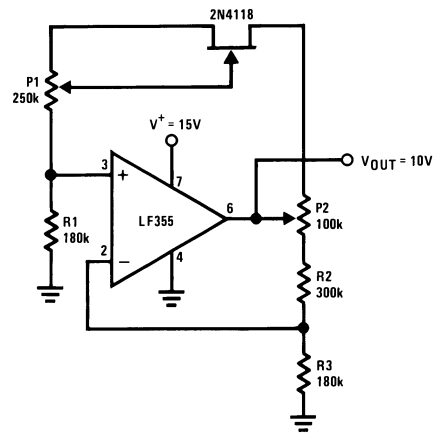

00564620

- $\Delta V_{OUT}/\Delta T = \pm 0.002\%/^{\circ}\text{C}$
- All resistors and potentiometers should be wire-wound
- P1: drift adjust
- P2: V_{OUT} adjust
- Use LF155 for
 - Low I_B
 - Low drift
 - Low supply current

Fast Logarithmic Converter

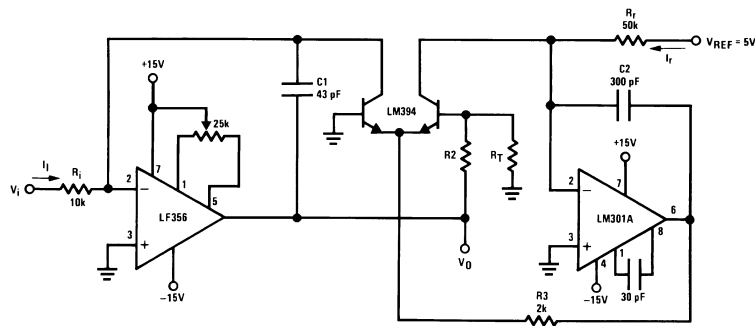

00564621

- Dynamic range: $100\mu\text{A} \leq I_i \leq 1\text{mA}$ (5 decades), $|V_O| = 1\text{V/decade}$
- Transient response: $3\mu\text{s}$ for $\Delta I_i = 1$ decade
- C1, C2, R2, R3: added dynamic compensation
- V_{OS} adjust the LF156 to minimize quiescent error
- R_T : Tel Labs type Q81 + $0.3\%/^{\circ}\text{C}$

$$|V_{OUT}| = \left[1 + \frac{R_2}{R_T} \right] \frac{kT}{q} \ln V_i \left[\frac{R_T}{V_{REF} R_i} \right] = \log V_i \frac{1}{R_i I_T} \quad R_2 = 15.7\text{k}, R_T = 1\text{k}, 0.3\%/^{\circ}\text{C} \text{ (for temperature compensation)}$$

Typical Applications (Continued)

Precision Current Monitor

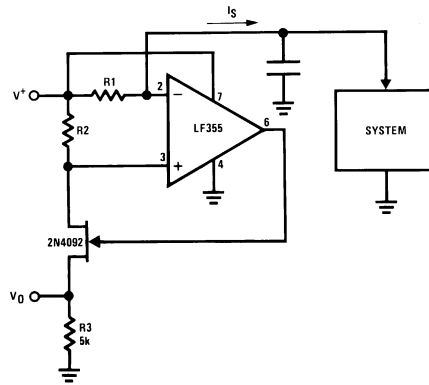

00564631

- $V_O = 5 R_1/R_2$ (V/mA of I_S)
- R1, R2, R3: 0.1% resistors
- Use LF155 for
 - Common-mode range to supply range
 - Low I_B
 - Low V_{OS}
 - Low Supply Current

8-Bit D/A Converter with Symmetrical Offset Binary Operation

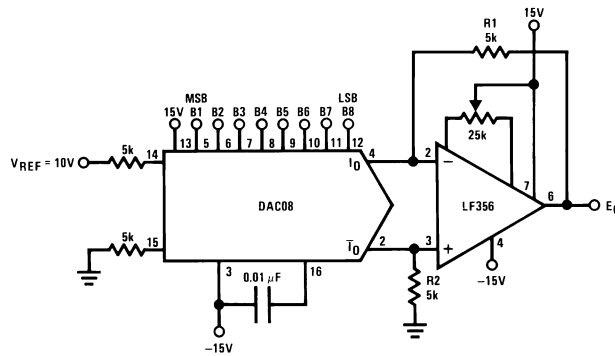

00564632

- R1, R2 should be matched within $\pm 0.05\%$
- Full-scale response time: 3 μ s

E_O	B1	B2	B3	B4	B5	B6	B7	B8	Comments
+9.920	1	1	1	1	1	1	1	1	Positive Full-Scale
+0.040	1	0	0	0	0	0	0	0	(+) Zero-Scale
-0.040	0	1	1	1	1	1	1	1	(-) Zero-Scale
-9.920	0	0	0	0	0	0	0	0	Negative Full-Scale

Typical Applications (Continued)

Wide BW Low Noise, Low Drift Amplifier

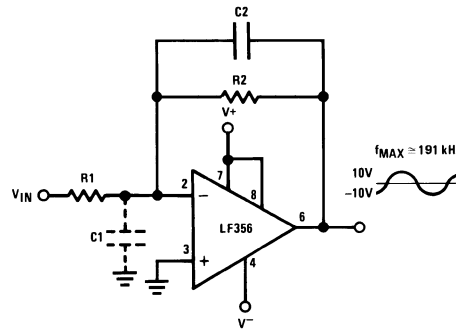

00564670

- Power BW: $f_{MAX} = \frac{S_r}{2\pi V_p} \cong 191 \text{ kHz}$

- Parasitic input capacitance $C1 \approx (3\text{pF for LF155, LF156 and LF357 plus any additional layout capacitance})$ interacts with feedback elements and creates undesirable high frequency pole. To compensate add $C2$ such that: $R2 C2 \approx R1 C1$.

Boosting the LF156 with a Current Amplifier

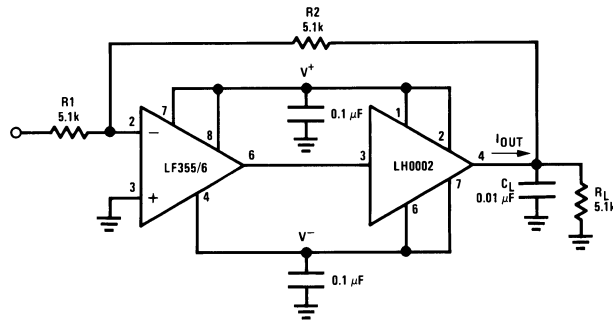

00564673

- $I_{OUT(MAX)} \approx 150\text{mA}$ (will drive $R_L \geq 100\Omega$)

- $\frac{\Delta V_{OUT}}{\Delta T} = \frac{0.15}{10^{-2}} \text{ V}/\mu\text{s}$ (with C_L shown)

- No additional phase shift added by the current amplifier

Typical Applications (Continued)

3 Decades VCO

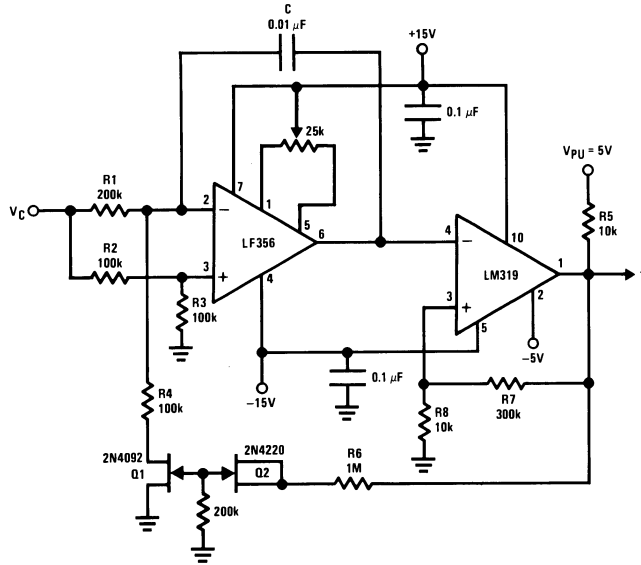

00564624

$$f = \frac{V_C (R8 + R7)}{(8 V_{PU} R8 R1) C'} \quad 0 \leq V_C \leq 30V, \quad 10 \text{ Hz} \leq f \leq 10 \text{ kHz}$$

R1, R4 matched. Linearity 0.1% over 2 decades.

Isolating Large Capacitive Loads

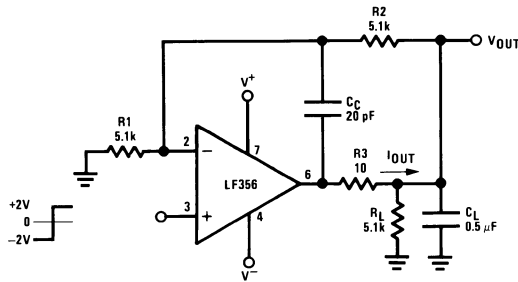

00564622

- Overshoot 6%
- t_s 10 μ s
- When driving large C_L , the V_{OUT} slew rate determined by C_L and $I_{OUT(MAX)}$:

$$\frac{\Delta V_{OUT}}{\Delta T} = \frac{I_{OUT}}{C_L} \cong \frac{0.02}{0.5} \text{ V}/\mu\text{s} = 0.04 \text{ V}/\mu\text{s} \text{ (with } C_L \text{ shown)}$$

Typical Applications (Continued)

Low Drift Peak Detector

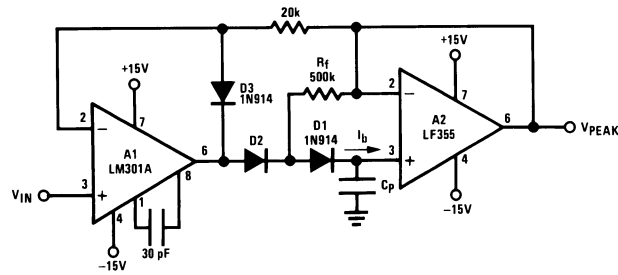

00564623

- By adding D1 and R_f , $V_{D1}=0$ during hold mode. Leakage of D2 provided by feedback path through R_f .
- Leakage of circuit is essentially I_b (LF155, LF156) plus capacitor leakage of C_p .
- Diode D3 clamps V_{OUT} (A1) to $V_{IN}-V_{D3}$ to improve speed and to limit reverse bias of D2.
- Maximum input frequency should be $\ll \frac{1}{2\pi R_f C_{D2}}$ where C_{D2} is the shunt capacitance of D2.

Non-Inverting Unity Gain Operation for LF157

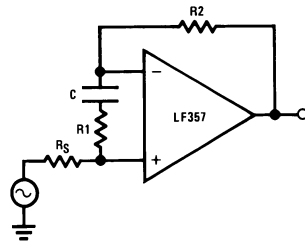

00564675

$$R1C \geq \frac{1}{(2\pi)(5 \text{ MHz})}$$

$$R1 = \frac{R2 + R_s}{4}$$

$$A_{V(DC)} = 1$$

$$f_{-3 \text{ dB}} \approx 5 \text{ MHz}$$

Inverting Unity Gain for LF157

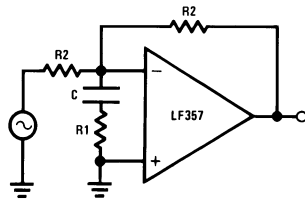

00564625

$$R1C \geq \frac{1}{(2\pi)(5 \text{ MHz})}$$

$$R1 = \frac{R2}{4}$$

$$A_{V(DC)} = -1$$

$$f_{-3 \text{ dB}} \approx 5 \text{ MHz}$$

Typical Applications (Continued)

High Impedance, Low Drift Instrumentation Amplifier

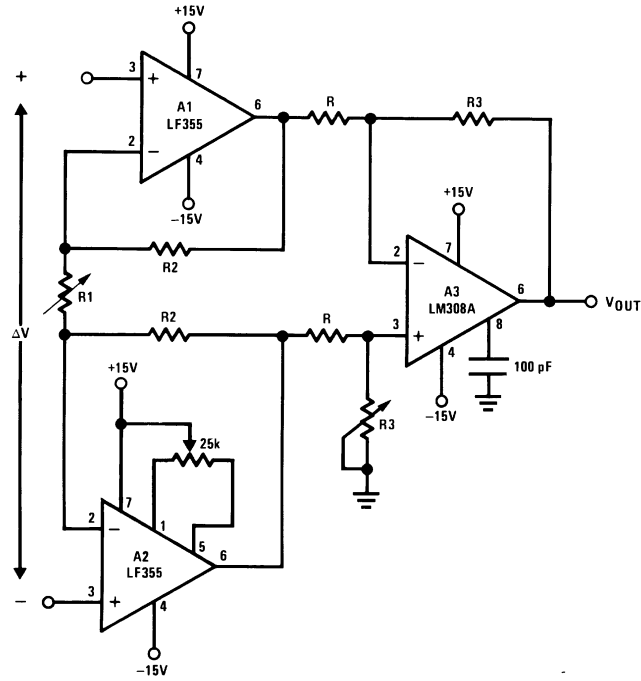

00564626

$$V_{OUT} = \frac{R3}{R} \left[\frac{2R2}{R1} + 1 \right] \Delta V, V^- + 2V \leq V_{IN \text{ common-mode}} \leq V^+$$

- System V_{OS} adjusted via A2 V_{OS} adjust
- Trim R3 to boost up CMRR to 120 dB. Instrumentation amplifier resistor array recommended for best accuracy and lowest drift

Typical Applications (Continued)

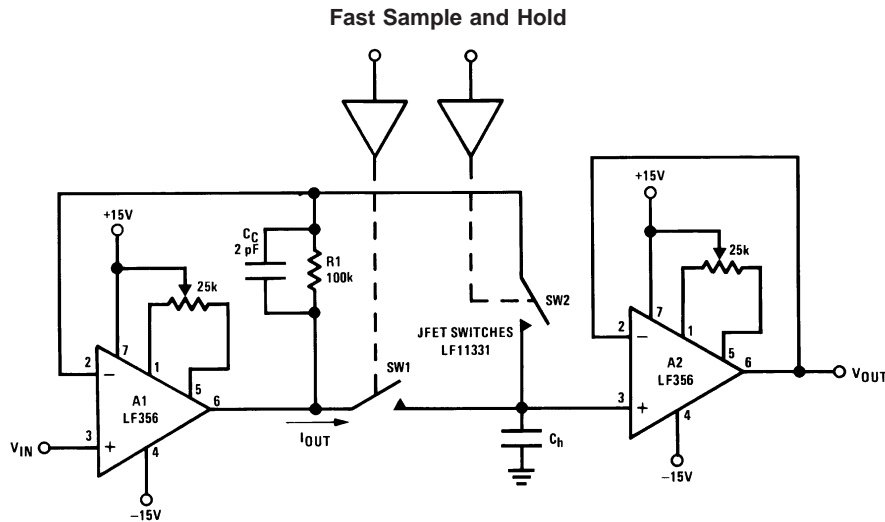

00564633

- Both amplifiers (A1, A2) have feedback loops individually closed with stable responses (overshoot negligible)
- Acquisition time T_A , estimated by:

$$T_A \cong \left[\frac{2R_{ON}, V_{IN}, C_h}{S_r} \right]^{1/2} \text{ provided that:}$$

$$V_{IN} < 2\pi S_r R_{ON} C_h \text{ and } T_A > \frac{V_{IN} C_h}{I_{OUT(MAX)}}, R_{ON} \text{ is of SW1}$$

$$\text{If inequality not satisfied: } T_A \cong \frac{V_{IN} C_h}{20 \text{ mA}}$$

- LF156 develops full S_r output capability for $V_{IN} \geq 1V$
- Addition of SW2 improves accuracy by putting the voltage drop across SW1 inside the feedback loop
- Overall accuracy of system determined by the accuracy of both amplifiers, A1 and A2

Typical Applications (Continued)

High Accuracy Sample and Hold

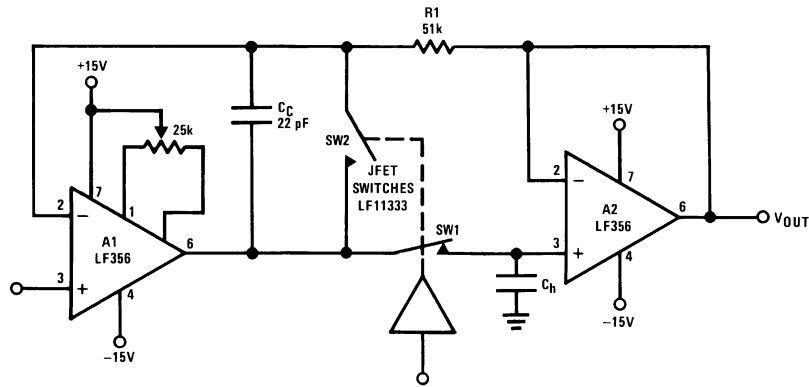

00564627

- By closing the loop through A2, the V_{OUT} accuracy will be determined uniquely by A1. No V_{OS} adjust required for A2.
- T_A can be estimated by same considerations as previously but, because of the added propagation delay in the feedback loop (A2) the overshoot is not negligible.
- Overall system slower than fast sample and hold
- R1, C_C : additional compensation
- Use LF156 for
 - Fast settling time
 - Low V_{OS}

High Q Band Pass Filter

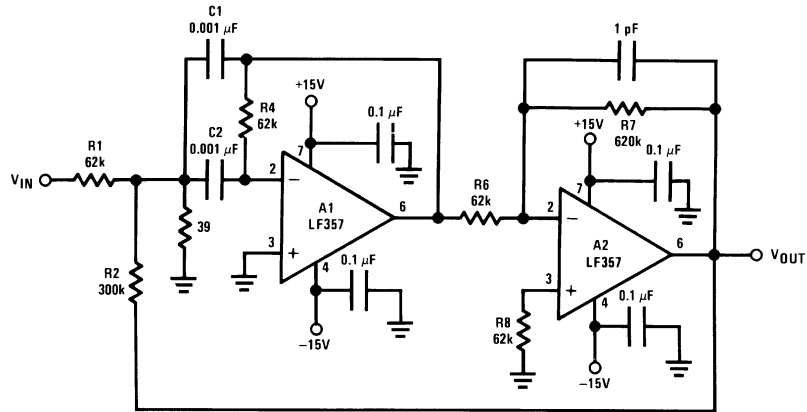

00564628

- By adding positive feedback (R2)
- Q increases to 40
- $f_{BP} = 100$ kHz

$$\frac{V_{OUT}}{V_{IN}} = 10\sqrt{Q}$$

- Clean layout recommended
- Response to a 1Vp-p tone burst: 300μs

Typical Applications (Continued)

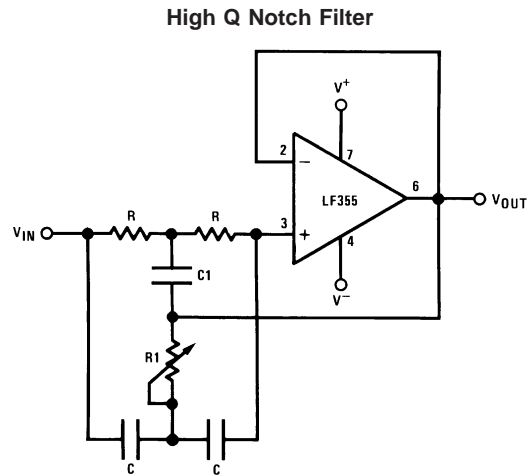

00564634

- $2R1 = R = 10M\Omega$
 $2C = C1 = 300pF$
- Capacitors should be matched to obtain high Q
- $f_{NOTCH} = 120\text{ Hz}$, notch = -55 dB, $Q > 100$
- Use LF155 for
 - Low I_B
 - Low supply current

Physical Dimensions inches (millimeters) unless otherwise noted

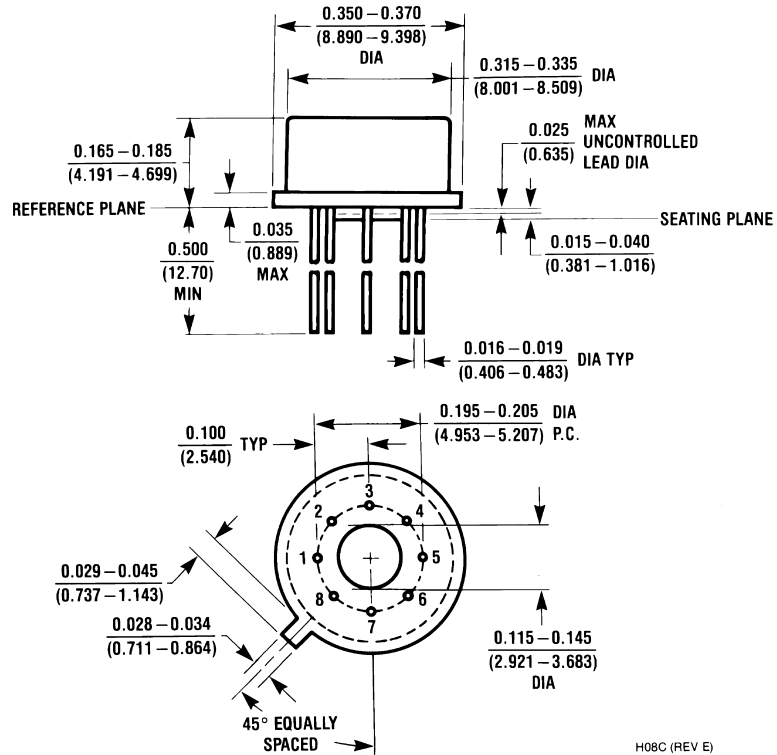

Metal Can Package (H)
 Order Number LF155H, LF156H, LF256H, LF257H, LF356BH, LF356H or LF357H
 NS Package Number H08C

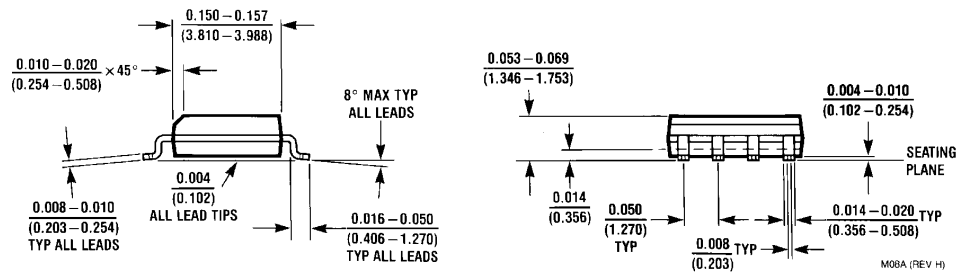
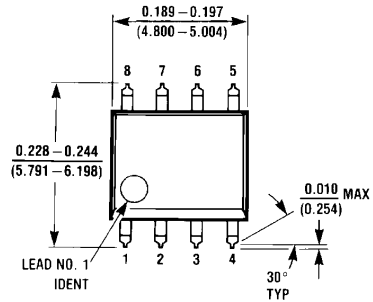

Small Outline Package (M)
 Order Number LF356M or LF356MX
 NS Package Number M08A

Physical Dimensions inches (millimeters) unless otherwise noted (Continued)

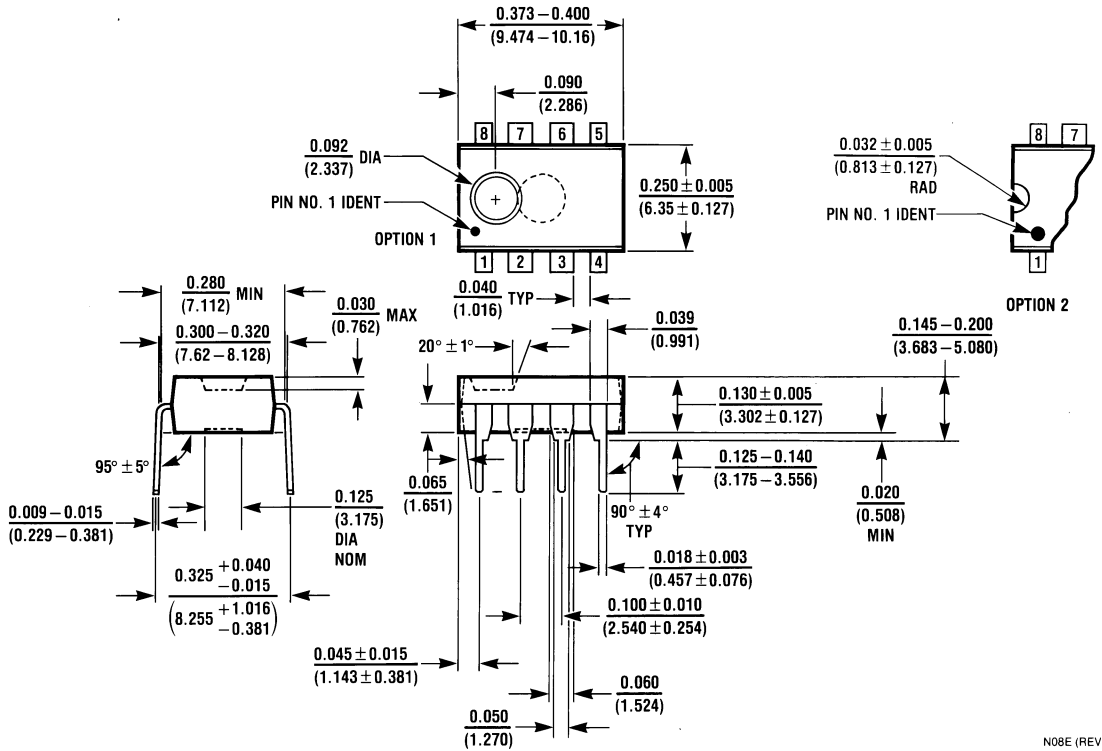

Molded Dual-In-Line Package (N)
Order Number LF356N
NS Package Number N08E

N08E (REV F)

LIFE SUPPORT POLICY

NATIONAL'S PRODUCTS ARE NOT AUTHORIZED FOR USE AS CRITICAL COMPONENTS IN LIFE SUPPORT DEVICES OR SYSTEMS WITHOUT THE EXPRESS WRITTEN APPROVAL OF THE PRESIDENT AND GENERAL COUNSEL OF NATIONAL SEMICONDUCTOR CORPORATION. As used herein:

1. Life support devices or systems are devices or systems which, (a) are intended for surgical implant into the body, or (b) support or sustain life, and whose failure to perform when properly used in accordance with instructions for use provided in the labeling, can be reasonably expected to result in a significant injury to the user.
2. A critical component is any component of a life support device or system whose failure to perform can be reasonably expected to cause the failure of the life support device or system, or to affect its safety or effectiveness.

 **National Semiconductor Corporation**
 Americas
 Email: support@nsc.com

National Semiconductor Europe
 Fax: +49 (0) 180-530 85 86
 Email: europe.support@nsc.com
 Deutsch Tel: +49 (0) 69 9508 6208
 English Tel: +44 (0) 870 24 0 2171
 Français Tel: +33 (0) 1 41 91 8790

National Semiconductor Asia Pacific Customer Response Group
 Tel: 65-2544466
 Fax: 65-2504466
 Email: ap.support@nsc.com

National Semiconductor Japan Ltd.
 Tel: 81-3-5639-7560
 Fax: 81-3-5639-7507

www.national.com