

微細設定可能、しかも薄型設計タイプ

18回転型サーメットリマ  
18 TURNS CERMET TRIMMERS

CT-94

RoHS 指令対応 RoHS compliant



■特長 FEATURES

- RoHS指令対応
- 厚み4.8 mmの薄型設計
- 18回転型による微細設定可能
- RoHS compliant
- Thin body design (4.8 mm thick)
- 18 turn, sealed, precision type

内部構造図 INTERNAL STRUCTURE

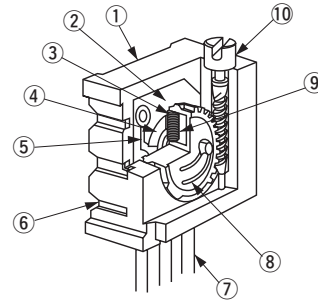

名称 Part name	材料 Material	燃焼性 Flammability
① ハウジング Housing	PBT (ポリブチレンテレフタレート) Polybutyleneterephthalate	UL-94V-0
② ベースエレメント Base element	セラミック Ceramic	—
③ ワイバ(摺動子) Wiper	多元合金 Multi metal alloy	
④ 抵抗体 Resistive element	RuO <sub>2</sub> サーメット RuO <sub>2</sub> cermet	
⑤ 電極体 Electrode	Ag-Pd サーメット Ag-Pd cermet	UL-94V-0
⑥ 接着剤 Adhesive	エポキシ Epoxy	
⑦ 端子 Terminal pin	銅、錫めっき Copper, Tin-plated	—
⑧ ロータギア Rotor gear	PA (ポリアミド) Polyamide	UL-94HB
⑨ ゴム板 Rubber cushion	シリコンゴム Silicone rubber	—
⑩ シャフト Shaft	黄銅、ニッケルめっき Brass, Nickel-plated	

■型式表示 PART NUMBER DESIGNATION

CT - 94 E W 1 k Ω ( 1 0 2 )

シリーズ名 Series name

端子 Terminal pin

E : 無鉛めっき品(鉛フリー対応) Sn (Lead-free)

製品形状 Product shape

W, Y : 上面調整 Top adjustment

X, P, Z : 側面調整 Side adjustment

抵抗値記号 Resistance code







抵抗値 Resistance value

※ご注文に際しては、型式一覧表をご確認ください。

Please refer to the LIST OF PART NUMBERS when placing orders.

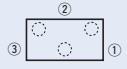
仕様は改善のために変更されることがありますので、ご注文の際は仕様をご確認ください。当カタログは参考仕様ですので、ご使用に際しては納入仕様書等の取り交わしをお願い致します。  
Specifications are subject to change without notice. Specifications in this catalog are for reference. The formal specification sheets will be submitted upon request.

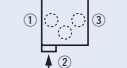
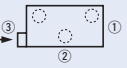
■型式一覧表 LIST OF PART NUMBERS

調整方向 Adjustment position	端子形状 (上面図) Shape of terminal (Top view)	包装形態 Form of packaging	包装数量 Pieces in package
		ポリ袋 Plastic bag	
上面調整 Top adjustment 		CT-94EW	50 pcs./pack
		CT-94EY	
側面調整 (↑調整面) Side adjustment (↑Adjustment direction)		CT-94EX	
		CP-94EP	
		CT-94EZ	
			

＜公称抵抗値 Nominal resistance values＞

⤵ 10 Ω	⤵ 20 Ω	50 Ω	100 Ω	200 Ω	500 Ω	1 kΩ	2 kΩ	5 kΩ	
10 kΩ	20 kΩ	⤵ 25 kΩ	50 kΩ	100 kΩ	200 kΩ	⤵ 250 kΩ	500 kΩ	1 MΩ	2 MΩ

Fig.1

※ご注文に際しては、〈公称抵抗値〉(Fig.1)について上記すべての組み合わせを用意しています。

※ご注文に際しては、上記型式をご確認ください。

※ The above part numbers are all available with the respective combination of <Nominal resistance values> (Fig. 1).

※ Verify the above part numbers when placing orders.

⤵印の公称抵抗値は受注生産となります。

The products indicated by ⤵ mark are manufactured upon receipt of order basis.

■機械的特性

MECHANICAL CHARACTERISTICS

調整ネジ回転数 Mechanical turn	18 turns
回転トルク Operating torque	35 mN·m {357 gf·cm} maximum
回転止 Mechanical stop	クラッチ動作 Clutch action
回転寿命 Rotational life	200 cycles [ ΔR/R ≤ ±(2 Ω + 3 %)]
端子強度 Terminal strength	10 N {1.02 kgf} minimum (引張り強さ Tensile strength)
操作部の押し強さ Thrust to shaft	10 N {1.02 kgf} minimum
はんだ付け性 Solderability	245 ± 3 °C, 2 ~ 3 s

{ } : 参考値 Reference only

■環境特性

ENVIRONMENTAL CHARACTERISTICS

試験項目 Test item	試験条件 Test conditions	仕様 Specifications
熱衝撃 Thermal shock	-65 ~ 125 °C (0.5 h), 5 cycles	[ ΔR/R ≤ 1 %] [S.S. ≤ 1 %]
耐湿性 Humidity	-10 ~ 65 °C (相対湿度80 ~ 98 %), 10 cycles, 240 h	[ ΔR/R ≤ 2 %]
耐衝撃性 Shock	981 m/s <sup>2</sup> , 6 ms 6 directions for 3 times each	[ ΔR/R ≤ 1 %] [S.S. ≤ 1 %]
耐振動性 Vibration	振幅 (Amplitude) 1.52 mm or 加速度 (Acceleration) 196 m/s <sup>2</sup> , 10 ~ 2000 Hz, 3 directions, 12 times each	
負荷寿命 Load life	70 °C, 0.5 W, 1000 h	[ ΔR/R ≤ 3 %] [S.S. ≤ 1 %]
低温動作 Low temp. operation	-55 °C, 2 h	[ ΔR/R ≤ 2 %] [S.S. ≤ 2 %]
高温放置 High temp. exposure	125 °C, 250 h	[ ΔR/R ≤ 3 %] [S.S. ≤ 2 %]
耐水、密閉性 Immersion seal	85 °C, 60 s	もれ無し(連続気泡無し) No leaks (No continuous bubbles)
はんだ耐熱性 Soldering heat	フロー : Flow soldering 260 ± 3 °C, 5 ~ 6 s, two times maximum 手はんだ : Manual soldering 380 ± 10 °C, 3 ~ 4 s	[ ΔR/R ≤ 1 %]

ΔR/R : 全抵抗値変化 Change in total resistance  
S.S. : 設定安定度 Setting stability

■電気的特性

ELECTRICAL CHARACTERISTICS

公称抵抗値範囲 Nominal resistance range	10 Ω ~ 2 MΩ
抵抗値許容差 Resistance tolerance	± 10 %
定格電力 Power ratings	0.5 W (70 °C) 0 W (125 °C)
抵抗変化特性 Resistance law	直線性 (B) Linear law
最大入力電圧 Maximum input voltage	DC300 V 又は 定格電力の何れか小さい方 DC300 V or power rating, whichever is smaller
最大ワイバ電流 Maximum wiper current	100 mA 又は 定格電力の何れか小さい方 100 mA or power rating, whichever is smaller
有効電気的回転数 Effective electrical turn	15 turns
残留抵抗値 End resistance	1 % 又は 2 Ω の何れか大きい方以下 1 % or 2 Ω, whichever is greater
接触抵抗変化 C.R.V.	1 % 又は 3 Ω の何れか大きい方以下 1 % or 3 Ω, whichever is greater
使用温度範囲 Operating temp. range	-55 ~ 125 °C
抵抗温度係数 Temp. coefficient	10 Ω, 20 Ω : ± 250 10 <sup>-6</sup> /°C maximum 50 Ω ~ 2 MΩ : ± 100 10 <sup>-6</sup> /°C maximum
絶縁抵抗 Insulation resistance	1000 MΩ minimum (DC500 V)
絶縁耐圧 Dielectric strength	AC900 V, 60 s
質量 Net weight	Approx. 0.88 g (CT-94EP) Approx. 0.92 g (CT-94EW, EX, EY, EZ)

# CT-94 CERMET TRIMMERS

## ■最大入力定格 MAXIMUM INPUT RATINGS

公称抵抗値 Nominal resistance values (Ω)	抵抗値記号 Resistance code	最大入力電圧 Maximum input voltage (V)	最大ワイパ電流 Maximum wiper current (mA)
➡ 10 ➡ 20 50 100 200 500	100 200 500 101 201 501	1.00 2.00 5.00 7.07 10.0 15.8	100 100 100 70.7 50.0 31.6
1 k 2 k 5 k 10 k ➡ 20 k ➡ 25 k 50 k	102 202 502 103 203 253 503	22.4 31.6 50.0 70.7 100 112 158	22.4 15.8 10.0 7.07 5.00 4.48 3.16
➡ 100 k ➡ 200 k ➡ 250 k ➡ 500 k 1 M 2 M	104 204 254 504 105 205	224 300 300 300 300 300	2.24 1.50 1.20 0.60 0.30 0.15

➡印の公称抵抗値は受注生産となります。  
The products indicated by ➡ mark are manufactured upon receipt of order basis.

## ■外形寸法図 OUTLINE DIMENSIONS

Unless otherwise specified, tolerance: ± 0.3 (Unit: mm)

### ● CT-94EW 上面調整 Top adjustment

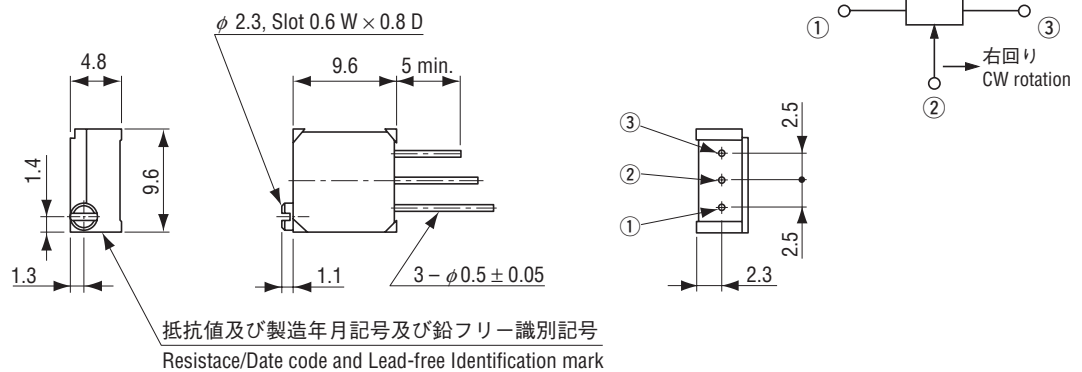

### ● CT-94EX 側面調整 Side adjustment

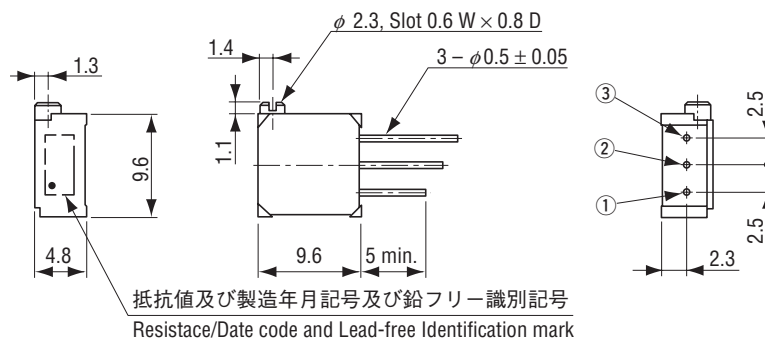

# CT-94 CERMET TRIMMERS

## 外形寸法図 OUTLINE DIMENSIONS

Unless otherwise specified, tolerance:  $\pm 0.3$  (Unit: mm)

### ● CT-94EP 側面調整 Side adjustment

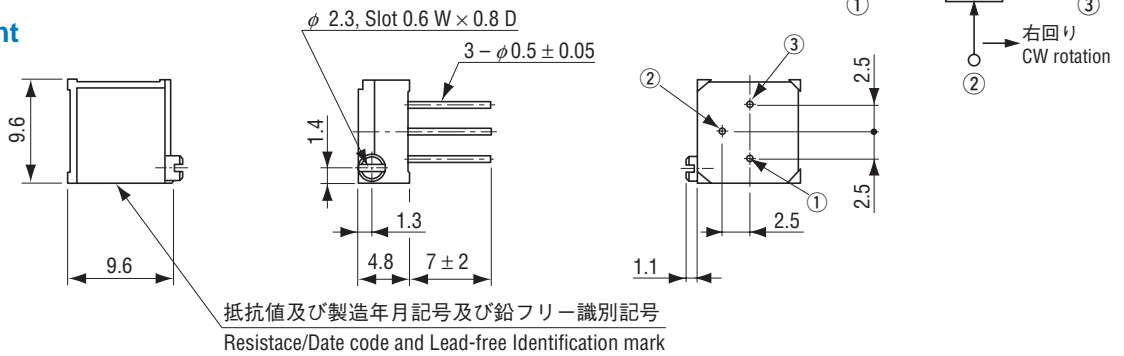

### ● CT-94EY 上面調整 Top adjustment

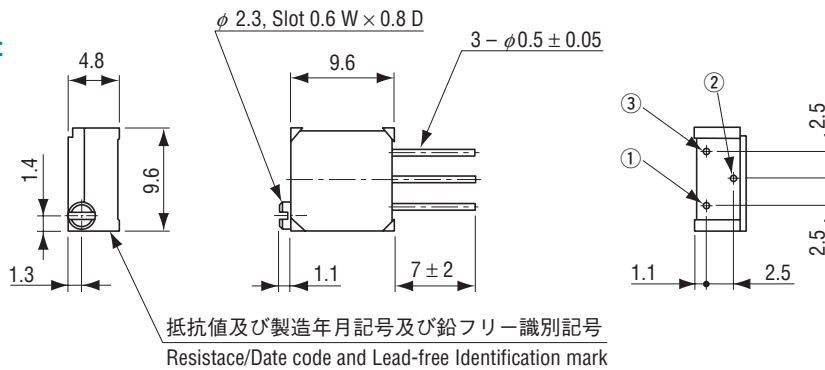

### ● CT-94EZ 側面調整 Side adjustment

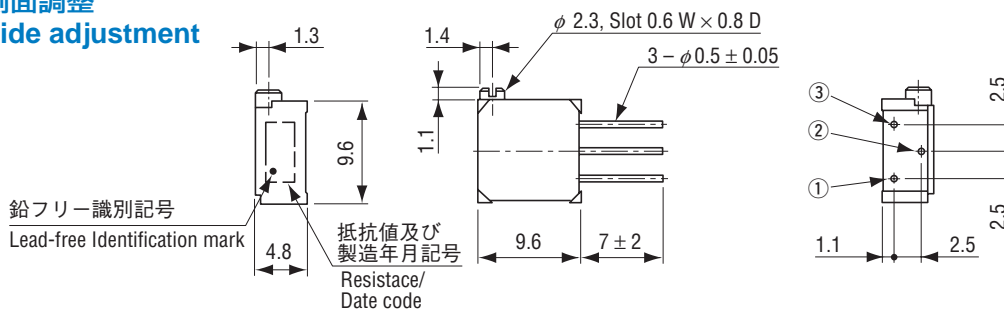

## 包装仕様

### <ポリ袋の包装仕様>

- ポリ袋での包装は、50個/袋となります。
- ポリ袋の箱詰めは、100個を製品箱に包装致します。

## PACKAGING SPECIFICATIONS

### <Bulk pack specifications>

- Unit of bulk in a plastic bag is 50 pcs. per pack.
- Boxing of bulk in a plastic bag is performed with 100 pcs. per box.