

豊富な種類で選べるローコスト汎用タイプ

1回転型サーメットリマ
SINGLE TURN CERMET TRIMMERS

CT-6

RoHS 指令対応 RoHS compliant

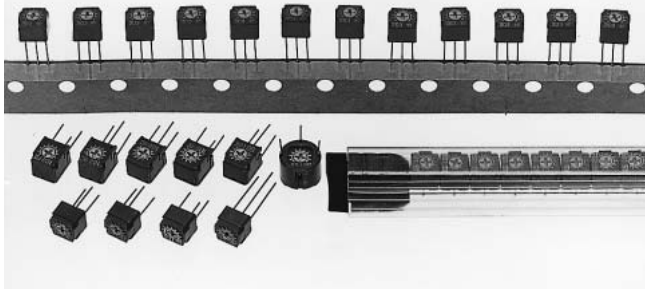

■特長 FEATURES

- RoHS指令対応
- 汎用タイプ
- 14種類の豊富なバリエーション
- 密閉型
- RoHS compliant
- Various configurations to choose from
- Wide variety (14 types)
- "O" ring sealed and washable

内部構造図 INTERNAL STRUCTURE

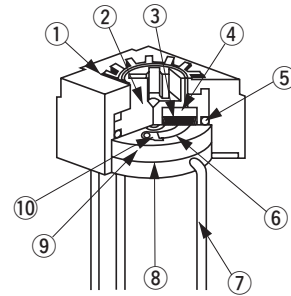





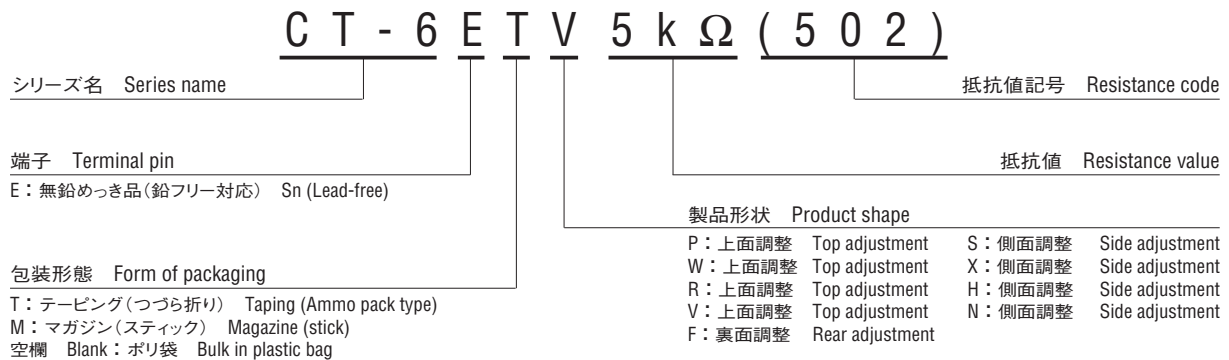





名称 Part name	材料 Material	燃焼性 Flammability
① ハウジング Housing	PBT (ポリブチレンテレフタレート) Polybutyleneterephthalate	UL-94V-0
② ロータ Rotor		
③ ワイバ (摺動子) Wiper	多元合金 Multi metal alloy	—
④ ゴム板 Rubber cushion	シリコンゴム Silicone rubber	
⑤ Oリング "O" ring	シリコンゴム Silicone rubber	UL-94HB
⑥ 抵抗体 Resistive element	RuO ₂ サーメット RuO ₂ cermet	—
⑦ 端子 Terminal pin	銅、錫めっき Copper, Tin-plated	
⑧ 接着剤 Adhesive	エポキシ Epoxy	UL-94V-0
⑨ ベースエレメント Base element	セラミック Ceramic	—
⑩ 電極体 Electrode	Ag-Pd サーメット Ag-Pd cermet	

■型式表示 PART NUMBER DESIGNATION



※ご注文に際しては、型式一覧表をご確認ください。
Please refer to the LIST OF PART NUMBERS when placing orders.

■ 型式一覧表 LIST OF PART NUMBERS

調整方向 Adjustment position	端子形状(上面図) Shape of terminal (Top view)	包装形態 Form of packaging			備考 Remarks
		テーピング Taping	マガジン(スティック) Magazine (stick)	ポリ袋 Plastic bag	
上面調整 Top adjustment 		CT-6ETP (つづら折り) Ammo pack type	CT-6EMP	CT-6EP	CT-6ETP、CT-6EMPとCT-6EPは、リードピンの長さがそれぞれ異なりますので、ご確認願います。 The pin length of CT-6ETP & CT-6EMP is different from CT-6EP.
				CT-6EW	—
				➡ CT-6ER	—
		CT-6ETV (つづら折り) Ammo pack type		CT-6EV	—
側面調整 (↑調整面) (↑ Adjustment direction)			CT-6EMS	CT-6ES	CT-6EMSとCT-6ESとは、リードピンの長さが異なりますので、ご確認願います。 The pin length of CT-6EMS is different from CT-6ES.
				CT-6EX	—
		CT-6ETH (つづら折り) Ammo pack type		CT-6EH	CT-6ETHとCT-6EHとは、リードピンの長さが異なりますので、ご確認願います。 The pin length of CT-6ETH is different from CT-6EH.
				CT-6EN	—
裏面調整 Rear adjustment				➡ CT-6EF	—
包装数量 Pieces in package		1000 pcs./taping	75 pcs./stick	50 pcs./pack	—

☒ : 製作不可能 Not manufactured

➡印の型式、公称抵抗値は受注生産となります。
The products indicated by ➡ mark are manufactured upon receipt of order basis.

- ※ご注文に際しては、〈公称抵抗値〉(Fig. 1)について上記すべての組み合わせを用意しています。
- ※ご注文に際しては、上記型式をご確認ください。
- ※テーピング及びマガジン仕様は、切り売り致しませんので、テーピング及びスティック単位でご注文をお願い致します。

〈公称抵抗値 Nominal resistance values〉

Fig. 1

➡ 10 Ω	➡ 20 Ω	50 Ω	100 Ω	200 Ω	500 Ω
1 kΩ	2 kΩ	5 kΩ	10 kΩ	20 kΩ	50 kΩ
100 kΩ	200 kΩ	500 kΩ	1 MΩ	2 MΩ	

- ※The above part numbers are all available with the respective combination of <Nominal resistance values> (Fig. 1).
- ※Verify the above part numbers when placing orders.
- ※Taping and magazine specifications are not sold separately and must be purchased in taping or stick units.

CT-6 CERMET TRIMMERS

■電気的特性 ELECTRICAL CHARACTERISTICS

公称抵抗値範囲 Nominal resistance range	10 Ω ~ 2 MΩ
抵抗値許容差 Resistance tolerance	± 10 %
定格電力 Power ratings	0.5 W (70 °C) 0 W (120 °C)
抵抗変化特性 Resistance law	直線性 (B) Linear law
最大入力電圧 Maximum input voltage	DC200 V 又は定格電力の何れか小さい方 DC200 V or power rating, whichever is smaller
最大ワイパ電流 Maximum wiper current	100 mA 又は定格電力の何れか小さい方 100 mA or power rating, whichever is smaller
有効電氣的回転角度 Effective electrical angle	220 ° (1 turn)
残留抵抗値 End resistance	1 % 又は 2 Ω の何れか大きい方以下 1 % or 2 Ω, whichever is greater
接触抵抗変化 C.R.V.	1 % 又は 3 Ω の何れか大きい方以下 1 % or 3 Ω, whichever is greater
使用温度範囲 Operating temp. range	-55 ~ 120 °C
抵抗温度係数 Temp. coefficient	10 Ω ~ 20 Ω : ± 250 10 ⁻⁶ /°C maximum 50 Ω ~ 2 MΩ : ± 100 10 ⁻⁶ /°C maximum
絶縁抵抗 Insulation resistance	1000 MΩ minimum (DC500 V)
絶縁耐圧 Dielectric strength	AC900 V, 60 s
質量 Net weight	Approx. 0.51 g (CT-6EP, EW, ER, EV) Approx. 0.65 g (CT-6ES, EX, EH, EN) Approx. 0.92 g (CT-6EF)

■機械的特性 MECHANICAL CHARACTERISTICS

機械的回転角度 Mechanical angle	260 ° (1 turn)
回転トルク Operating torque	2 ~ 20 mN·m (20 ~ 204 gf·cm)
回転止強度 Stop strength	50 mN·m (510 gf·cm) minimum
回転寿命 Rotational life	200 cycles [ΔR/R ≤ ± (2 Ω + 3 %)]
端子強度 Terminal strength	10 N (1.02 kgf) minimum (引張り強さ Tensile strength)
操作部の押し強さ Thrust to rotor	10 N (1.02 kgf) minimum
はんだ付け性 Solderability	245 ± 3 °C, 2 ~ 3 s

{ } : 参考値 Reference only

■環境特性 ENVIRONMENTAL CHARACTERISTICS

試験項目 Test item	試験条件 Test conditions	仕様 Specifications
熱衝撃 Thermal shock	-65 ~ 125 °C (0.5 h), 5 cycles	[ΔR/R ≤ 1 %] [S.S. ≤ 1 %]
耐湿性 Humidity	-10 ~ 65 °C (相対湿度80 ~ 98 %), 10 cycles, 240 h	[ΔR/R ≤ 2 %]
耐衝撃性 Shock	981 m/s ² , 6 ms 6 directions for 3 times each	[ΔR/R ≤ 1 %] [S.S. ≤ 1 %]
耐振動性 Vibration	振幅 (Amplitude) 1.52 mm or 加速度 (Acceleration) 196 m/s ² , 10 ~ 2000 Hz, 3 directions, 12 times each	
負荷寿命 Load life	70 °C, 0.5 W, 1000 h	[ΔR/R ≤ 3 %] [S.S. ≤ 1 %]
低温動作 Low temp. operation	-55 °C, 2 h	[ΔR/R ≤ 2 %] [S.S. ≤ 2 %]
高温放置 High temp. exposure	120 °C, 250 h	[ΔR/R ≤ 3 %] [S.S. ≤ 2 %]
耐水、密閉性 Immersion seal	85 °C, 60 s	もれ無し (連続気泡無し) No leaks (No continuous bubbles)
はんだ耐熱性 Soldering heat	フロー Flow : 260 ± 3 °C, 5 ~ 6 s, two times maximum 手はんだ Manual soldering : 380 ± 10 °C, 3 ~ 4 s	[ΔR/R ≤ 1 %]

ΔR/R : 全抵抗値変化 Change in total resistance
S.S. : 設定安定度 Setting stability

■最大入力定格 MAXIMUM INPUT RATINGS

公称抵抗値 Nominal resistance values (Ω)	抵抗値記号 Resistance code	最大入力電圧 Maximum input voltage (V)	最大ワイパ電流 Maximum wiper current (mA)
↻ 10 ↻ 20 50 100 200 500	100 200 500 101 201 501	1.00 2.00 5.00 7.07 10.0 15.8	100 100 100 70.7 50.0 31.6
1 k 2 k 5 k 10 k 20 k 50 k	102 202 502 103 203 503	22.4 31.6 50.0 70.7 100 158	22.4 15.8 10.0 7.07 5.00 3.16
100 k 200 k 500 k 1 M 2 M	104 204 504 105 205	200 200 200 200 200	2.00 1.00 0.40 0.20 0.10

↻印の公称抵抗値は受注生産となります。
The products indicated by ↻ mark are manufactured upon receipt of order basis.

CT-6 CERMET TRIMMERS

■外形寸法図 OUTLINE DIMENSIONS

Unless otherwise specified, tolerance: ± 0.3 (Unit: mm)

● CT-6EP 上面調整 Top adjustment

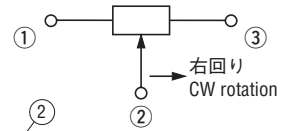
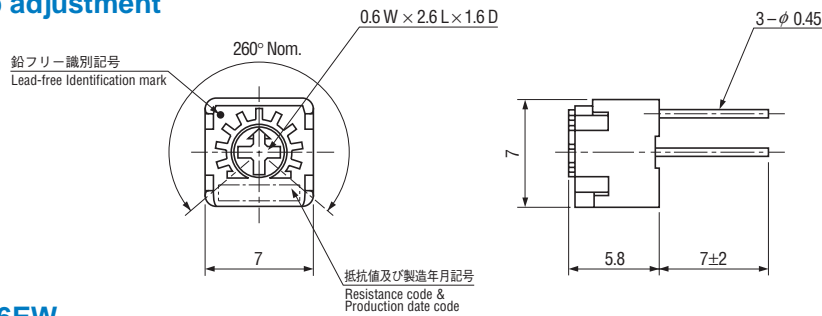

● CT-6EW 上面調整 Top adjustment

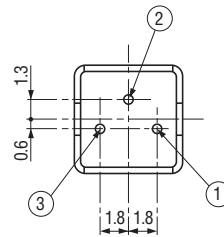
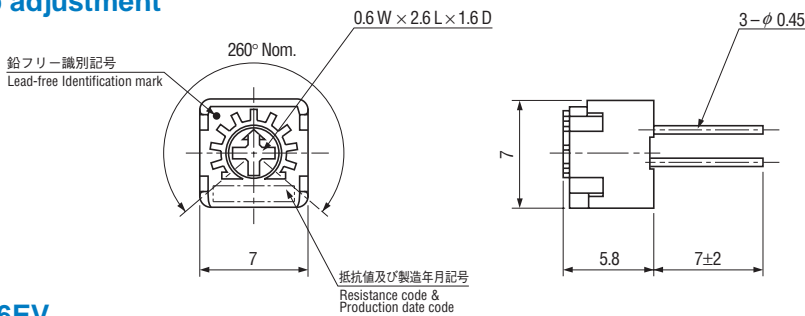

● CT-6EV 上面調整 Top adjustment

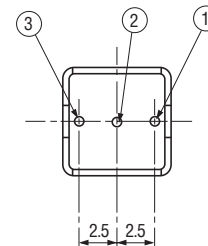
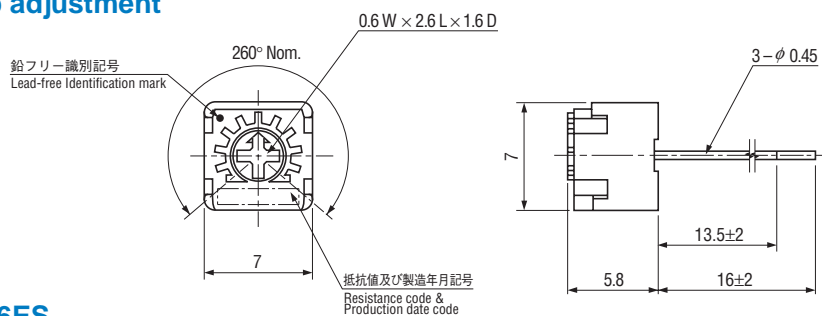

★P型とピンピッチが異なります。
Pin pitch in W type is different from P type.

● CT-6ES 側面調整 Side adjustment

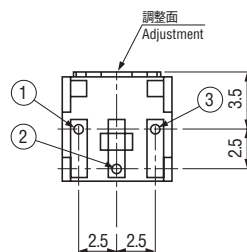
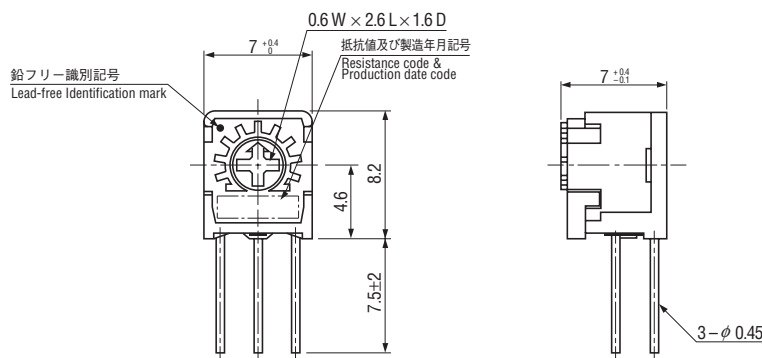

CT-6 CERMET TRIMMERS

■外形寸法図 OUTLINE DIMENSIONS

● CT-6EX 側面調整 Side adjustment

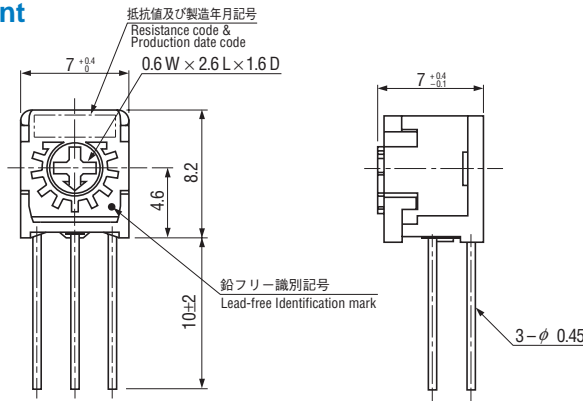

Unless otherwise specified, tolerance: ± 0.3 (Unit: mm)

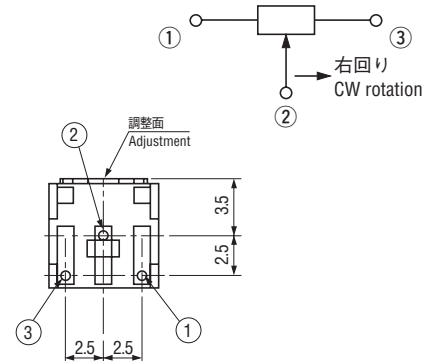

● CT-6EH 側面調整 Side adjustment

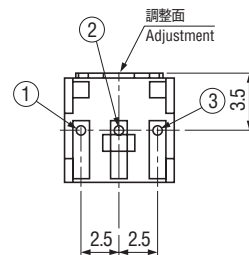
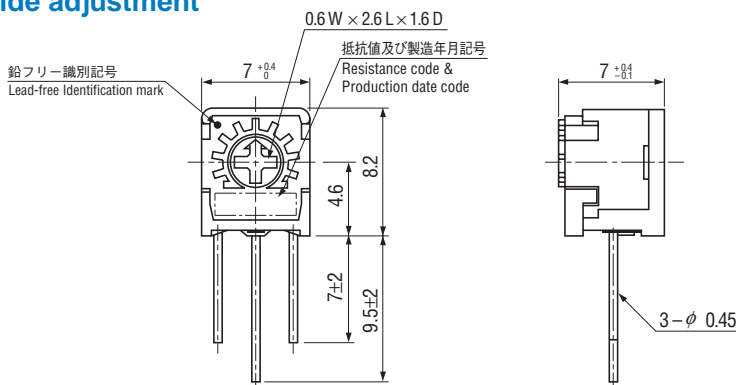

● CT-6EN 側面調整 Side adjustment

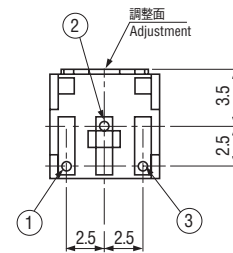
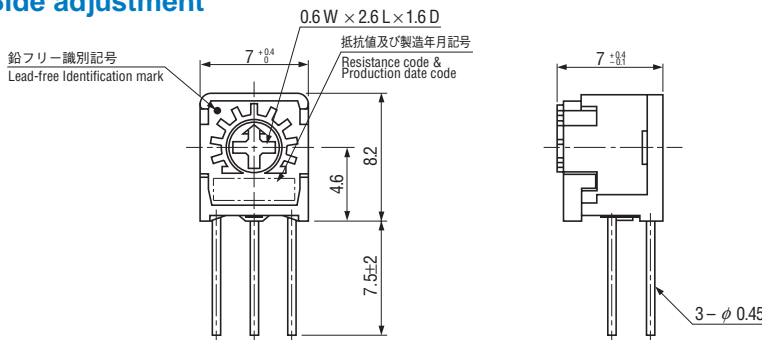

★X型と1番、3番端子の配置が異なります。
Terminals ① & ③ position in N type is different from X type.

CT-6 CERMET TRIMMERS

■外形寸法図 OUTLINE DIMENSIONS

Unless otherwise specified, tolerance: ± 0.3 (Unit: mm)

● CT-6EF 裏面調整 Rear adjustment

<受注生産品 Semi-standard products>

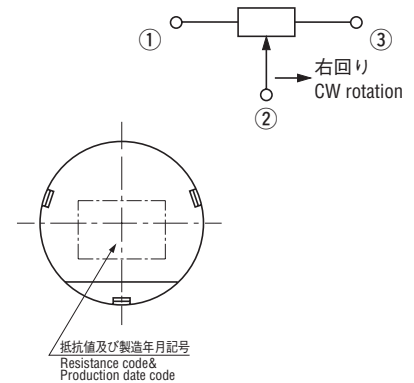
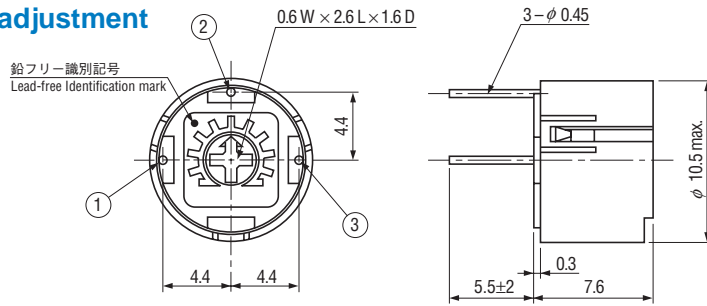

● CT-6ER 上面調整 Top adjustment

<受注生産品 Semi-standard products>

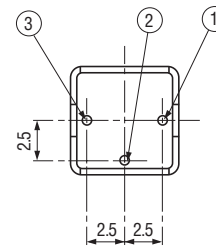
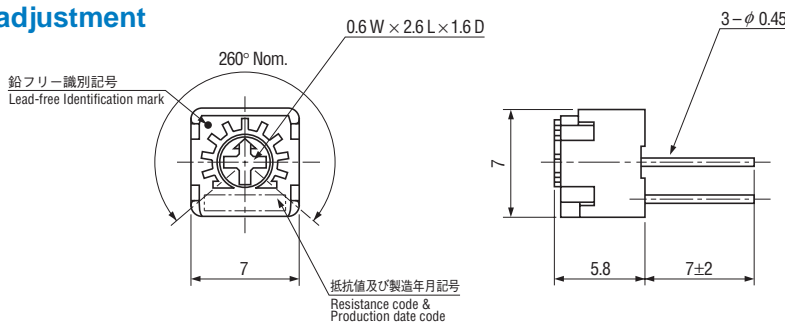

■包装仕様

<テーピングの包装仕様>

- テーピングは1000個/テーピング単位の包装となりますので、1000個単位 (1000個、2000個、3000個...) でのご注文をお願い致します。
- テーピングの箱詰め品は、1000個ごとにつづら折り箱に包装致します。

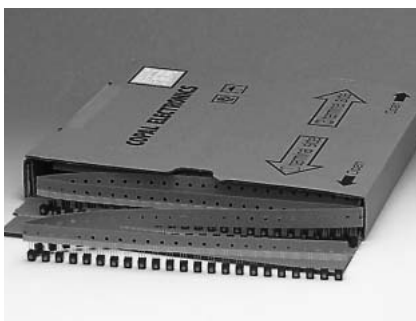

つづら折り
Ammo pack type

つづら折り Ammo Pack

- 箱の寸法は、330 mm × 330 mm × 45 mmです。
- テーピングの初めと終わりのリーダ部は、300 mm以上とします。
- 製品の取り出し口は、2箇所あり、箱に矢印で表示しています。1番端子側の矢印方向からは、製品の1番端子が先に引き出され、3番端子側の矢印方向からは、製品の3番端子が先に引き出されます。
- 包装時質量 ETV : 約840 g
ETH : 約930 g
ETP : 約850 g

■PACKAGING SPECIFICATIONS

<Taping packaging specifications>

- Taping version is packaged in 1000 pcs. per reel. Orders will be accepted for units of 1000 pcs., i.e., 1000, 2000, 3000 pcs., etc.
- Taping version (ammo pack type) is boxed with one reel (1000 pcs.).

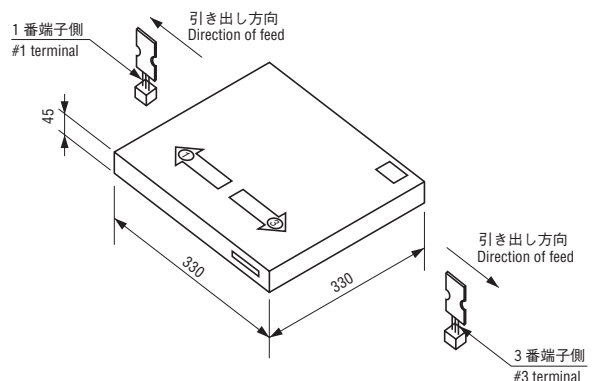

- Package size: 330 mm × 330 mm × 45 mm
- The leader and end of the tape have an empty part of minimum 300 mm respectively.
- There are two tape outlets on the package for different terminal alignment directions, for which details refer to the sketch above. (e.g.) When the tape is fed from the right outlet marked ③, #3 terminal comes out first.
- Gross weight of the boxing version ETV : Approx. 840 g
ETH : Approx. 930 g
ETP : Approx. 850 g

仕様は改善のために変更されることがありますので、ご注文の際は仕様をご確認ください。当カタログは参考仕様ですので、ご使用に際しては納入仕様書等の取り交わしをお願い致します。
Specifications are subject to change without notice. Specifications in this catalog are for reference. The formal specification sheets will be submitted upon request.

CT-6 CERMET TRIMMERS

● CT-6ETV
上面調整
Top adjustment

Unless otherwise specified, tolerance: ± 0.3 (Unit: mm)

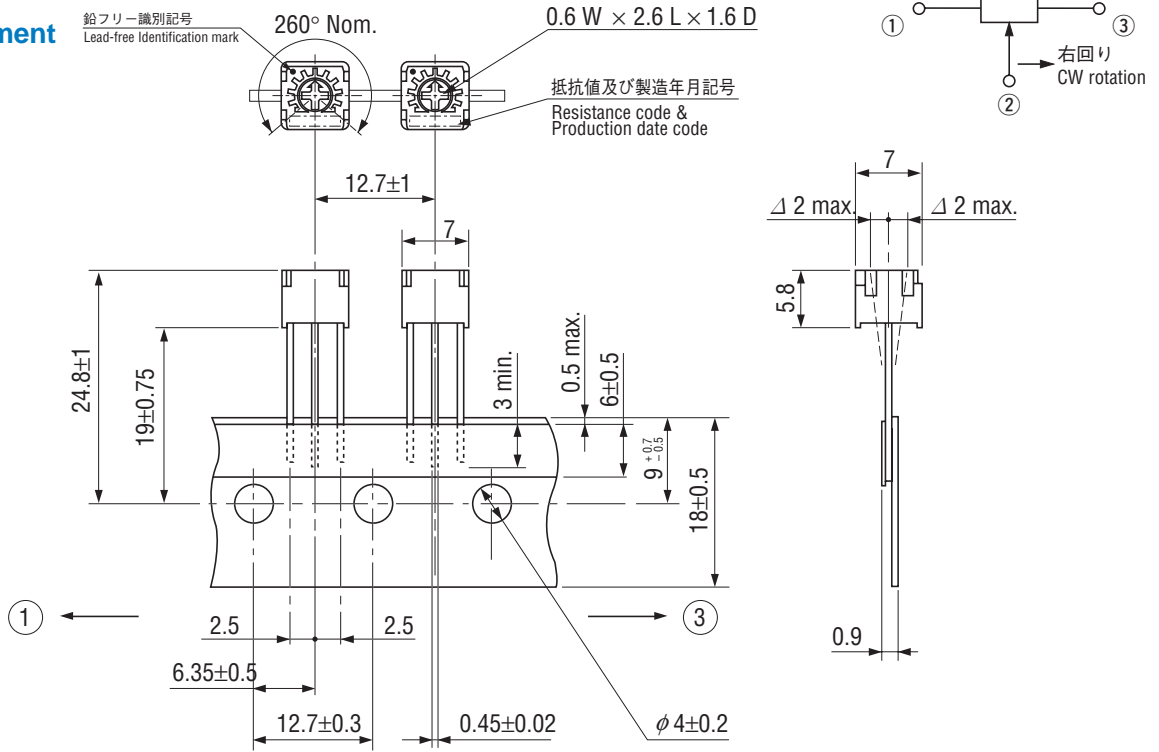

● CT-6ETH
側面調整
Side adjustment

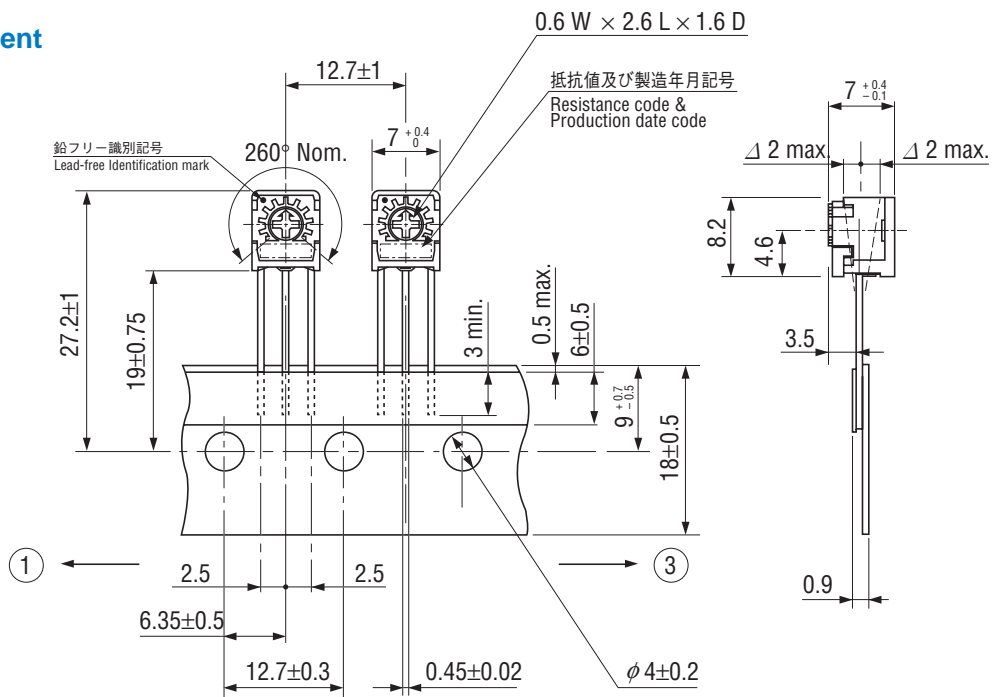

CT-6 CERMET TRIMMERS

● **CT-6ETP**
上面調整
Top adjustment

Unless otherwise specified, tolerance: ± 0.3 (Unit: mm)

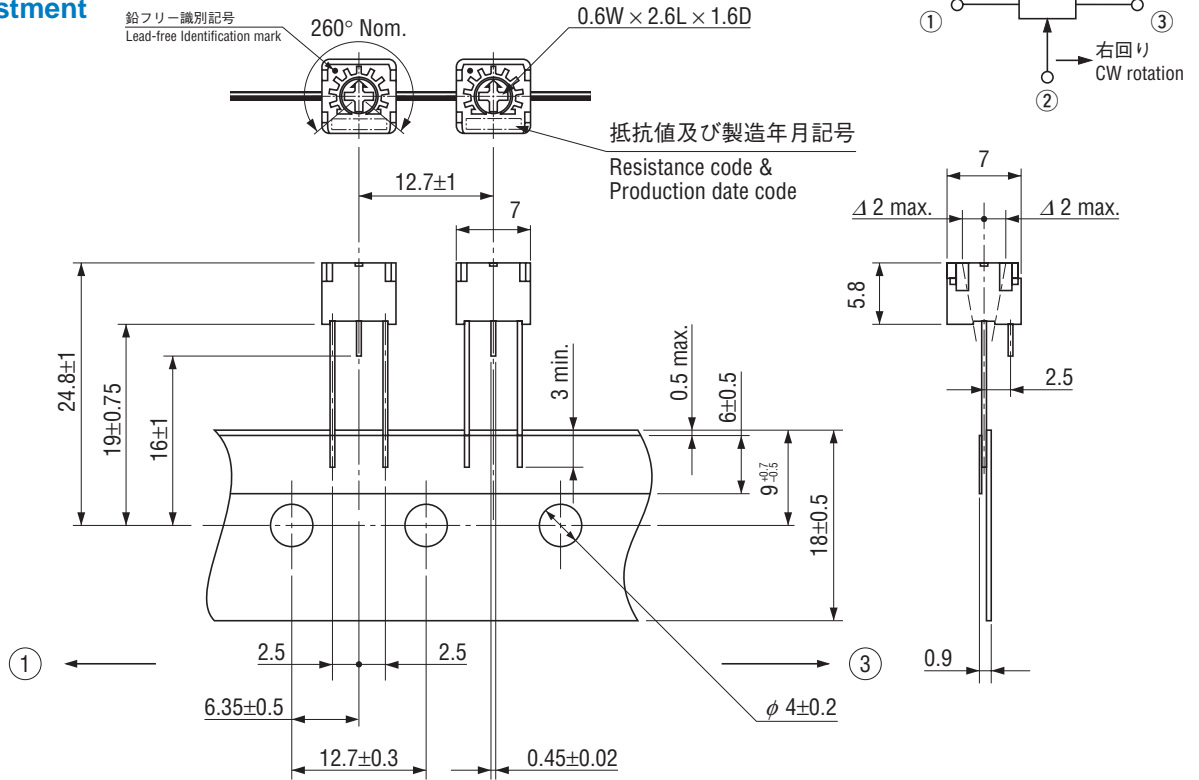

<マガジンの包装仕様>

- マガジンは75個/スティック単位の包装となりますので、75個単位(150個、225個...)でのご注文をお願い致します。
- マガジンの箱詰めは、3000個をマガジン箱に包装致します。

<Magazine packaging specifications>

- Magazine is packaged 75 pcs. per stick. Orders will be accepted for units of 75 pcs. i.e., 150, 225 pcs., etc.
- Magazine is packed 3000 pcs. sticks per box.



Plastic magazine type

参考値 <Typical>
Plastic magazine length = 580 mm
(Without rubber cap)

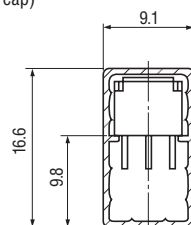

CT-6EMP

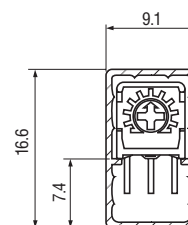

CT-6EMS

CT-6 CERMET TRIMMERS

● CT-6EMP 上面調整 Top adjustment

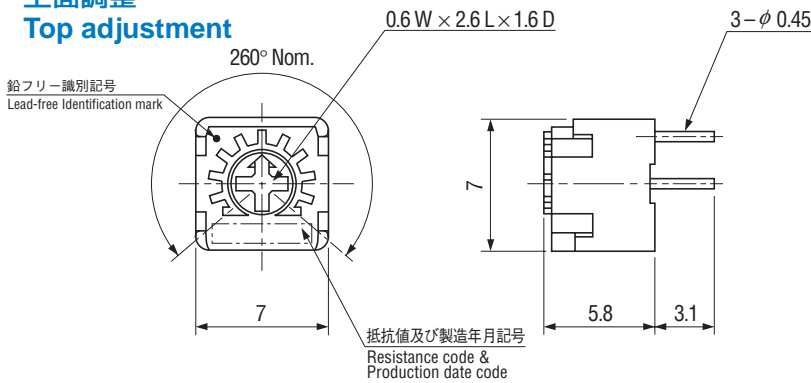

Unless otherwise specified, tolerance: ± 0.3 (Unit: mm)

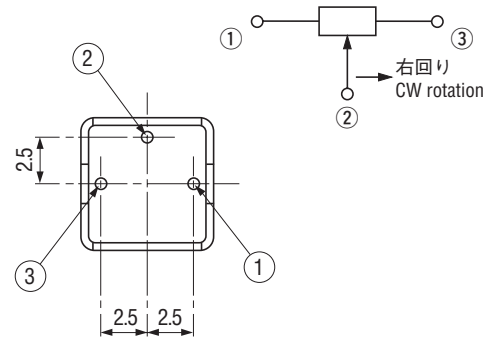

● CT-6EMS 側面調整 Side adjustment

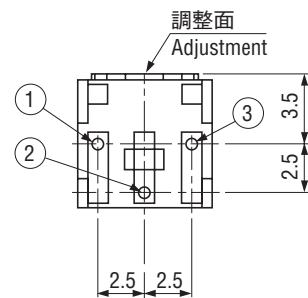
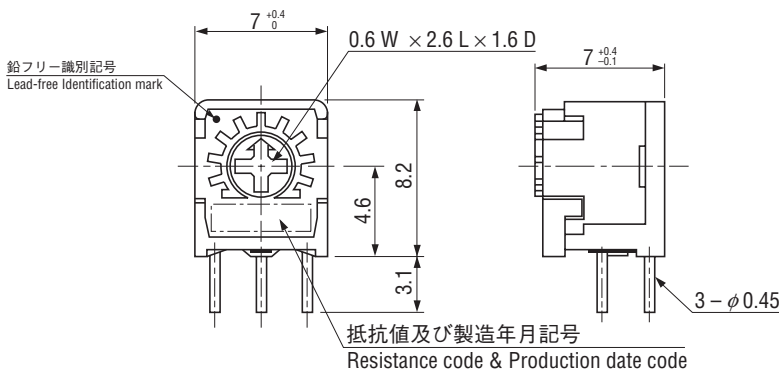

<ポリ袋の包装仕様>

- ポリ袋での包装は、50個/袋となります。
- ポリ袋の箱詰めは、200個 (CT-6EFは100個) を製品箱に包装致します。

<Bulk pack specifications>

- Unit of bulk pack in a plastic bag is 50 pcs. per pack.
- Boxing of bulk in a plastic bag is performed with 200 pcs. (CT-6EF is 100 pcs.) per box.

■ トリマ調整用ドライバ TA-64 ADJUSTMENT TOOL, MODEL TA-64

Unless otherwise specified, tolerance: ± 0.3 (Unit: mm)

- 1本で、プラスドライバ、マイナスドライバの2つの機能。
- 下表の当社トリマの調整に使用できます。
- Good for both minus and cross slot rotors / shafts.
- Recommended for use with the following copal trimmers.

適用機種 Recommended models	
+ bit	- bit
CT-6	ST-4
FT-63	RJ-4
	RJ-6
	TM-7

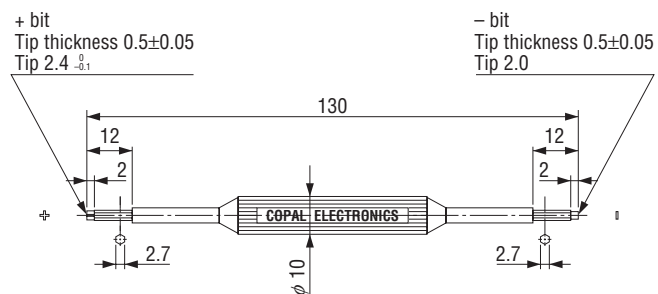

材質：POM (ポリオキシメチレン)
Material : Polyoxymethylene

※注意：電子部品の調整用途以外では、ご使用しないでください。

Note : Please do not use the tool for purposes other than adjustment of electronic components.

■ 仕様は改善のために変更されることがありますので、ご注文の際は仕様をご確認ください。当カタログは参考仕様ですので、ご使用に際しては納入仕様書等の取り交わしをお願い致します。
Specifications are subject to change without notice. Specifications in this catalog are for reference. The formal specification sheets will be submitted upon request.