

2SA473

PNP EPITAXIAL SILICON TRANSISTOR

LOW FREQUENCY POWER AMPLIFIER

● Complement to 2SC1173

ABSOLUTE MAXIMUM RATINGS ($T_A=25^\circ\text{C}$)

Characteristic	Symbol	Rating	Unit
Collector-Base Voltage	V_{CB0}	-30	V
Collector-Emitter Voltage	V_{CE0}	-30	V
Emitter-Base voltage	V_{EB0}	-5	V
Collector Current (DC)	I_C	-3	A
Collector Dissipation ($T_c=25^\circ\text{C}$)	P_C	10	W
Junction Temperature	T_j	150	$^\circ\text{C}$
Storage Temperature	T_{stg}	-50~150	$^\circ\text{C}$

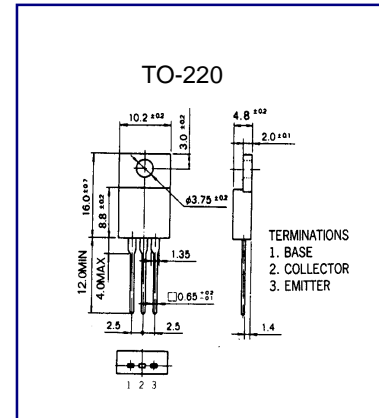

ELECTRICAL CHARACTERISTICS ($T_A=25^\circ\text{C}$)

Characteristic	Symbol	Test Condition	Min	Typ	Max	Unit
Collector Cutoff Current	I_{CB0}	$V_{CB} = -30V, I_E = 0$			-10	μA
Emitter Cutoff Current	I_{EB0}	$V_{EB} = -5V, I_C = 0$			10	μA
DC Current Gain	h_{FE1}	$V_{CE} = -1V, I_C = -0.1A$	70		240	
Collector- Emitter Saturation Voltage	$V_{CE(sat)}$	$I_C = -2A, I_B = -0.2A$			-0.8	V
Current Gain Bandwidth Product	f_T	$V_{CE} = -2V, I_C = -0.5A$		100		MHZ